



Alliance Storage Technologies, Inc. User Manual

Plasmon® Brand Archive Appliance and Gx Series Libraries

P/N 800-103858-00 Rev 01

PREFACE

Copyright

Copyright 2012 by Alliance Storage Technologies Inc. All rights reserved. This item and the information contained herein are the property of Alliance. No part of this document may be reproduced, transmitted, transcribed, stored in a retrieval system, or translated into any language or computer language in any form or by any means, electronic, mechanical, magnetic, optical, chemical, manual or otherwise, without the express written permission of Alliance.

Alliance Technical Support Team
United States Calls: 1-877-585-6973
International Calls: 01-719-593-4437
Fax: 1-719-593-4164
Email: tech.support@astiusa.com
Internet: www.astiusa.com

Disclaimer

Alliance makes no representation or warranties with respect to the contents of this document and specifically disclaims any implied warranties of merchantability or fitness for any particular purpose. Further, Alliance reserves the right to revise this publication without obligation of Alliance to notify any person or organization of such revision or changes.

Trademark Notices

Plasmon and UDO are U.S. registered trademarks of Alliance Storage Technologies, Inc. All other names are trademarks or registered trademarks of their respective owners.

Revision History

Revision	Date	Description
A	7/2012	Initial Release, Combined 102305 & 102616 +Elite
01	5/2013	New Rev Scheme, rear 80, 174 foot, AA pwr-up/dn, SCSI, added A2 specs, LEDs.

NOTE

The most current information about this product is available on the Alliance web site (www.astiusa.com).

Conventions Used

WARNING



A **WARNING** is used to alert the reader to situations or conditions that could potentially result in personal injury, fire hazard, or equipment damage.

CAUTION



A **CAUTION** is used to warn of undesirable procedures, or of situations in which equipment damage could result.

NOTE

A **NOTE** is used to emphasize an area of text or to provide additional information.

WEEE Compliance

Alliance products with the Waste Electrical and Electronic Directive (WEEE) label, shown below, can be shipped back to Alliance for proper disposal of hazardous components. Please contact Alliance Technical Support at the locations listed inside the back cover of this manual for the proper procedure.



Product Warranty

The Plasmon library is warranted free from defects in materials, parts and workmanship and to conform to the current product specification upon delivery. For the specific details of your warranty, refer to your sales contract or contact the company from which the library was purchased.

The Alliance quality system is in compliance with and registered to ISO9001:2000. All products are assembled from new or remanufactured parts.

The warranty for the library shall not apply to failures of any unit when:

- The library is repaired by anyone other than Alliance personnel or approved agent.
- The library is physically abused or is used in a manner that is inconsistent with the operating instructions or product specification defined by Alliance.
- The library fails because of accident, misuse, abuse, neglect, mishandling, misapplication, alteration, faulty installation, modification, or service by anyone other than the factory service center or its approved agent.
- The library is repaired by anyone, including an approved agent, in a manner that is contrary to the maintenance or installation instructions supplied by Alliance.
- The Alliance serial number tag is removed.
- The library is damaged because of improper packaging on return.

CAUTION



Returning the library in unauthorized packaging may damage the unit and void the warranty.

If problems with the library occur, contact your maintenance organization; do not void the product warranty by allowing untrained or unauthorized personnel to attempt repairs.

WARNING



Untrained personnel operating the library may create dangerous situations. This could lead to physical harm to the operator, data loss, and/or disabling of the library system. Please review and observe all safety statements concerning the operation of the library.

TABLE OF CONTENTS

PREFACE	3
COPYRIGHT	3
DISCLAIMER	3
TRADEMARK NOTICES	3
REVISION HISTORY	4
CONVENTIONS USED	5
WEEE COMPLIANCE	5
PRODUCT WARRANTY	6
TABLE OF CONTENTS	7
LIST OF FIGURES	11
LIST OF TABLES	12
CHAPTER 1 PRODUCT OVERVIEW	13
GENERAL INFORMATION	13
Gx LIBRARY MODELS	14
COMMAND PROCESSING	15
MEDIA MOVEMENT	15
IMPORTING AND EXPORTING MEDIA	15
UDO DRIVE TYPE	16
DRIVE CLEANING CARTRIDGES	16
UDO MEDIA	18
WRITE PROTECTING UDO MEDIA	18
BARCODE LABEL	19
MEDIA CARE AND HANDLING	20
MAJOR HARDWARE COMPONENTS	21
FRONT PANEL DISPLAY	31
IO STATION	31
DRIVES	31
SCSI INTERFACE	31
LIFT LOCK SCREW	31
POWER CONNECTOR	31
MEDIA STORE	31
MEDIA TRANSPORT ASSEMBLY (MTA)	31
OPTIONAL SCSI REDRIVE CIRCUIT BOARD	32
OPTIONAL SMS	32
CHAPTER 2 LIBRARY INSTALLATION	33
GETTING STARTED	33
UNPACKING THE LIBRARY	33
LIBRARY POSITION	33
LIBRARY ENVIRONMENT	33
EXTERNAL POWER REQUIREMENTS	33
LIBRARY STABILIZERS	34
INSTALLING THE LEG STABILIZERS – ALL MODELS	34

INSTALLING THE Gx100 – 174 AND AA100 - 174 SERIES FRONT STABILIZERS	35
LIFT LOCK SCREW	36
POWER CONNECTION	37
POWER CORD RETAINER	37
Gx SCSI CONNECTION	39
External Host SCSI to Library	39
Internal A12 SMS SCSI	39
Internal E12 SMS SCSI	39
External SMS SCSI to Optional Extension Library	39
LOADING MEDIA	40
BULK LOADING MEDIA	40
IO STATION MEDIA LOADING	41
INITIAL POWER ON: NON-AA LIBRARY SYSTEMS	42
HOST COMPUTER	42
IDENTIFYING STORAGE SLOTS	42
RACK MOUNT GUIDELINES	47
REQUIRED TOOLS	48
RACK MOUNT KIT	49
RACK MOUNT INSTALLATION	50
STABILIZER INSTALLATION	51
SHELF INSTALLATION	53
LIBRARY INSTALLATION	57
PACKING INSTRUCTIONS	63
CHAPTER 3 MENU SYSTEM (GX MODELS ONLY)	69
<hr/>	
NAVIGATING THE MENU SYSTEM	69
POWER UP MENU OPTIONS	71
MENU SYSTEM OVERVIEW	72
MAIN MENU OVERVIEW	73
LIBRARY STATUS MENU OVERVIEW	74
SET UP LIBRARY MENU OVERVIEW	77
MAINTENANCE MODE MENU OVERVIEW	80
CHAPTER 4 AA PRODUCT INFORMATION	85
<hr/>	
GENERAL INFORMATION	85
A12	85
E12 ELITE	85
IAC A2	85
ARCHIVE APPLIANCE CONFIGURATIONS	86
MAJOR HARDWARE COMPONENTS	87
IAC SMS & IAC POWER SUPPLY OPTION	91
FRONT PANEL DISPLAY	92
MAILSLOT	92
UDO DRIVES	92
SMS	92
SATA DRIVES	92
SAS DRIVES	92
LIFT LOCK SCREW	92
POWER CONNECTOR	92
MEDIA STORE	92

MEDIA TRANSPORT ASSEMBLY (MTA)	92
INSTALLING THE RAID HARD DISK DRIVES	93
SMS CABLE CONNECTIONS	94
AA SYSTEM INITIAL POWER ON	96
AA SYSTEM POWER-DOWN	96
SMS LED INDICATORS	97
<u>APPENDIX A GX SERIES SPECIFICATIONS</u>	<u>99</u>
GX SERIES LIBRARIES	99
AA-A2 IAC SERIES LIBRARIES	103
AA-A12 SERIES LIBRARIES	105
AA-E12 SERIES LIBRARIES	107
<u>APPENDIX B SCSI BUS INFORMATION</u>	<u>109</u>
SCSI BUS CONFIGURATION	109
SCSI ID CONFIGURATION	112
<i>SCSI CABLE APPLICATIONS</i>	112
SCSI CABLES	113
SCSI Redrive Option	114
<u>APPENDIX C SAFETY AGENCY STANDARDS</u>	<u>115</u>
FCC NOTICE	115
INDUSTRY CANADA NOTICE PER ICES-003	115
EUROPEAN NOTICE	115
AUSTRALIA/NEW ZEALAND NOTICE	116
JAPAN NOTICE	116
PRC NOTICE	116
PRODUCT SAFETY STANDARDS	116
CDRH REGULATIONS	117
LASER SAFETY NOTICE	117
LITHIUM BATTERY	118
DISPOSAL INSTRUCTIONS FOR RETIRED SYSTEMS:	118
POWER SOURCE SAFETY	119
EARTH GROUNDING	119
In Norway	119
In Sweden	119
In Finland	119
POWER CORD SET	120
U.S. and Canada	120
Germany and continental Europe	120
MOV PROTECTION FUSES	120
UNINTERRUPTABLE POWER SOURCE	121
<u>APPENDIX D</u>	<u>122</u>
<u>ERROR CODES</u>	<u>122</u>
ERROR CODES	122
ERROR CODE LIST	123
ERROR SUBCODE LIST	128

INDEX	131
CONTACTING ALLIANCE	133
FIRMWARE UPDATES	133
BEFORE PLACING A CALL TO ALLIANCE	133
PLACING A SERVICE CALL	133

LIST OF FIGURES

FIGURE 1. UDO DRIVE TYPES	16
FIGURE 2. UDO MEDIA.....	18
FIGURE 3. WRITE PROTECTING UDO MEDIA.....	18
FIGURE 4. TYPE 2 BARCODE LABEL FORMAT AND PLACEMENT	19
FIGURE 5. Gx24, 32 SERIES LIBRARIES, SINGLE COLUMN, FRONT VIEW.....	21
FIGURE 6. Gx24, 32 SERIES LIBRARIES, SINGLE COLUMN, REAR VIEW.....	22
FIGURE 7. Gx24, 32 SERIES LIBRARIES, SINGLE COLUMN, INSIDE VIEW	23
FIGURE 8. Gx20, 40, 60, 72, 80 SERIES LIBRARIES, DUAL COLUMN, FRONT VIEW	24
FIGURE 9. Gx20, 40, 60, 72, 80 SERIES LIBRARIES, DUAL COLUMN, REAR VIEW	25
FIGURE 10. ELITE AA20, 40, 60, 72, 80 SERIES LIBRARIES, REAR VIEW	26
FIGURE 11. Gx20, 40, 60, 72, 80 SERIES LIBRARIES, DUAL COLUMN, INSIDE VIEW.....	27
FIGURE 12. Gx100, 120, 134, 140, 158, 166, 174 SERIES LIBRARIES, DUAL COLUMN, FRONT VIEW	28
FIGURE 13. Gx100, 120, 134, 140, 158, 166, 174 SERIES LIBRARIES, DUAL COLUMN, REAR VIEW	29
FIGURE 14. Gx100, 120, 134, 140, 158, 166, 174 SERIES LIBRARIES, INSIDE VIEW.....	30
FIGURE 15. SCSI REDRIVE CIRCUIT BOARD	32
FIGURE 16. Gx20 – Gx80 SERIES SIDE STABILIZERS	34
FIGURE 17. Gx100 – 174, AA100-174 AND ELITE AA100-174 SERIES FRONT STABILIZER.....	35
FIGURE 18. LIFT LOCK AND POWER CONNECTOR FOR Gx LIBRARIES	36
FIGURE 19. INSTALLING THE POWER CORD RETAINER.....	37
FIGURE 20. INSTALLING THE POWER CORD RETAINER.....	38
FIGURE 21. INSTALLING THE POWER CORD RETAINER.....	38
FIGURE 22. . LOADING MEDIA USING THE IO STATION	41
FIGURE 23. FRONT PANEL DISPLAY AT POWER ON	42
FIGURE 24. Gx24 – Gx32 SLOT DIAGRAM	43
FIGURE 25. Gx20 - 80 SERIES SLOT DIAGRAM	44
FIGURE 26. Gx134 SLOT DIAGRAM.....	45
FIGURE 27. Gx174 SLOT DIAGRAM.....	46
FIGURE 28. PACKING THE Gx LIBRARIES	63
FIGURE 29. PACKING THE Gx LIBRARIES	64
FIGURE 30. PACKING THE Gx LIBRARIES	64
FIGURE 31. PACKING THE Gx LIBRARIES	65
FIGURE 32. PACKING THE Gx LIBRARIES	65
FIGURE 33. PACKING THE Gx LIBRARIES	66
FIGURE 34. PACKING THE Gx LIBRARIES	66
FIGURE 35. PACKING THE Gx LIBRARIES	67
FIGURE 36. PACKING THE Gx LIBRARIES	67
FIGURE 37. PACKING THE Gx LIBRARIES	68
FIGURE 38. Gx174 STRAPPING HOLES IN SKID.....	68
FIGURE 39. LCD DISPLAY FORMAT	69
FIGURE 40. POWER UP LCD DISPLAY	71
FIGURE 41. MENU SYSTEM OVERVIEW	72
FIGURE 42. MAIN MENU OVERVIEW.....	73
FIGURE 43. LIBRARY STATUS MENU OPTIONS	74
FIGURE 44. SET UP LIBRARY MENU OPTIONS	77
FIGURE 45. MAINTENANCE MODE MENU OPTIONS	80
FIGURE 46. . ELITE SMS UNIT ON 174 LIBRARY.....	85
FIGURE 47. AA80A12, FRONT VIEW	87
FIGURE 48. AA80A12, REAR VIEW	88
FIGURE 49. AA16 & AA32 WITH IAC A2 ARCHIVE CONTROLLER	89
FIGURE 50. AA174A12, FRONT VIEW	90
FIGURE 51. AA174A12, REAR VIEW	91
FIGURE 52. DRIVE RELEASE LEVER AND LOCK (SATA HDDs SHOWN)	93
FIGURE 53. A12 SMS UNIT BACK PANEL.....	94
FIGURE 54. E12 ELITE SMS UNIT BACK PANEL	95

FIGURE 55. A12 SMS LED INDICATORS	97
FIGURE 56. A12 SATA HDD LED INDICATORS	97
FIGURE 57. E12 SAS HDD LED INDICATORS	97
FIGURE 58. A2 SMS LED LEGEND LABEL	98
FIGURE 59. SCSI BUS CONFIGURATION FOR THE Gx (2 DRIVES)	109
FIGURE 60. SCSI BUS CONFIGURATION FOR THE Gx (4 DRIVES)	110
FIGURE 61. SCSI BUS CONFIGURATION FOR THE Gx100 – Gx174 (6 DRIVES).....	111
FIGURE 62. SURGE PROTECTION MODULE FUSES.....	120
FIGURE 63. ERROR INDICATOR ON DISPLAY	122
FIGURE 64. ERROR CODE ON DISPLAY	122

LIST OF TABLES

TABLE 1. Gx24-Gx174 LIBRARY MODELS	14
TABLE 2. LIBRARY FIRMWARE REQUIRED TO CLEAN UDO2 DRIVES	17
TABLE 3. LIBRARY RACK SIZE CHART	47
TABLE 4. RACK MOUNT KIT PART NUMBERS/DESCRIPTIONS.....	49
TABLE 5. LCD SYMBOLS.....	70
TABLE 6. POWER UP LCD SYMBOLS	71
TABLE 7. MAIN MENU SELECTIONS.....	73
TABLE 8. LIBRARY STATUS MENU SELECTIONS	75
TABLE 9. SET UP LIBRARY MENU SELECTIONS.....	78
TABLE 10. MAINTENANCE MODE MENU SELECTIONS	81
TABLE 11. . ARCHIVE APPLIANCE CONFIGURATIONS	86
TABLE 12. ARCHIVE CONTROLLER LED SIGNALS	98
TABLE 13. Gx24 – 32 AND Gx20 - 80 SERIES LIBRARY SPECIFICATIONS	99
TABLE 14. Gx174 SERIES LIBRARY SPECIFICATIONS.....	101
TABLE 15. AA32 A2 & AA80 A2 SERIES SPECIFICATIONS	103
TABLE 16. AA174 A2 SERIES SPECIFICATIONS.....	104
TABLE 17. AA80 A12 SERIES SPECIFICATIONS	105
TABLE 18. AA174 A12 SERIES SPECIFICATIONS	106
TABLE 19. AA80 ELITE SERIES SPECIFICATIONS	107
TABLE 20. AA174 ELITE SERIES SPECIFICATIONS	108
TABLE 21. FACTORY DEFAULT SCSI IDS FOR THE Gx (2 DRIVES).....	112
TABLE 22. FACTORY DEFAULT SCSI IDS FOR THE Gx (4 DRIVES).....	112
TABLE 23. FACTORY DEFAULT SCSI IDS FOR THE Gx100 – Gx174 (6 DRIVES)	112
TABLE 24. SCSI CABLE LENGTHS (Gx24 – Gx32 SERIES).....	113
TABLE 25. SCSI CABLE LENGTHS (Gx20 – 80 SERIES)	113
TABLE 26. SCSI CABLE LENGTHS (Gx100 – Gx174 SERIES).....	113
TABLE 27. POWER CORD SET REQUIREMENTS	120
TABLE 28. LOCAL UPS REQUIREMENTS	121
TABLE 29. ERROR CODES.....	123
TABLE 30. SUBCODES	128

CHAPTER 1

PRODUCT OVERVIEW

General Information

The RoHS compliant Plasmon Gx libraries make multiple UDO™ (Ultra Density Optical) media available to computer systems for reading or writing. The libraries have media storage capacities ranging from 20 to 174 media, providing up to 10.44TB of data storage. Media is easily added or removed through an automated IO station located above the library's front door. The libraries have a media transport assembly (MTA) with a dual picker, which can move two media simultaneously, to make rapid media exchanges and provide increased performance in a multi-user environment. Three chassis sizes are offered.

As an option, Gx libraries also support MO (Magnetic Optical) drives and media. Both UDO and MO drives and media can co-exist in the same library, on the same bus, if the library control software supports this feature.

The Plasmon Archive Appliance™ is a RoHS compliant Gx library with an integrated Storage Management System (SMS) network attached device. Three SMS product series are available: the A12 Series, the accelerated performance E12 Elite Series and the IAC A2. These units combine the performance benefits of network attached RAID with the reliability and robustness of Plasmon UDO™ (Ultra Density Optical) optical storage. The Archive Appliance runs enterprise class storage management software. (See Chapter 4, page 85, of this manual for all Archive Appliance specific description and the appendix, page 99, for specifications.)

This manual addresses the hardware portion of the system. For details regarding the SMS with complete software configuration information, please refer to the Plasmon Archive Appliance SMS Administration Guide.

Gx Library Models

This section covers the following Plasmon libraries:

Table 1. Gx24-Gx174 Library Models

Model	Maximum Media Capacity	MAX Drive Capacity
Gx24	24	2
Gx32	32	2
Gx20	20	4
Gx40	40	4
Gx60	60	4
Gx72	72	4
Gx80	80	2
Gx100	100	6
Gx120	120	6
Gx134	134	4
Gx140	140	6
Gx158	158	6
Gx166	166	4
Gx174	174	2

NOTE

On Gx80 and Gx174, increasing the drive count greater than two affects the number of available storage slots. Gx24 and Gx32 models have single column chassis. Models above Gx80 have tall chassis.

Command Processing

The library responds to SCSI commands from a host computer to load and unload drives and move media within the library. The host computer must have a dedicated LVD SCSI host bus adapter.

Media Movement

The media transport assembly (MTA) is used to move media within the library between the media storage area and a drive or the IO station. To speed up the process, the MTA has a dual picker to move two media simultaneously.

Importing and Exporting Media

Single media are imported or exported using the IO station. The IO station operation is controlled by the single application software on the host computer, or through menu options on the front panel display.

To import media, insert the cartridge fully into the IO station with the shutter facing in, and issue the appropriate command to the library. When media is fully inserted, the front panel display indicates media present in the IO station.

UDO Drive Type

Plasmon Gx Libraries can have UDO30, UDO60, or both UDO drive types installed. The drive type is indicated on the drive bezel, visible inside the library, as shown in the pictures below. The drives are also labeled by type inside the front door of the libraries. UDO30 drives read and write only 30GB media. UDO60 drives read and write 60GB media, and can read 30GB media.



Figure 1 UDO Drive Types

Drive Cleaning Cartridges

A special Plasmon UDO30GB Drive Cleaning Cartridge (part number 160-101300-00) is orderable for all UDO libraries containing UDO1 drives. This cartridge should be used only as recommended by an Alliance support technician. This cleaning cartridge is for use in UDO1 drives only. It should not be used in UDO2 drives. It provides a dry, contact cleaning method. No liquid or cleaning solution of any kind should be used with this cartridge.

A special Plasmon UDO60GB Drive Cleaning Cartridge (part number 160-103322-00) is shipped with all UDO libraries containing UDO2 drives. This cartridge should be used only as recommended by an Alliance support technician. This cleaning cartridge is for use in UDO2 drives only. It should not be used in UDO1 drives. It provides a dry, contact cleaning method. No liquid or cleaning solution of any kind should be used with this cartridge. Table 2 gives the minimum firmware versions required to clean UDO2 drives.

Table 2. Library Firmware Required to Clean UDO2 Drives

Libraries	<i>Firmware Versions</i>
Gx24-Gx80	G05e ⁽¹⁾
Gx134-Gx174	HO6e ⁽¹⁾

(1) Alliance always recommends using the latest firmware revision.

After each use, a check box must be marked on the appropriate side of the cartridge. When all check boxes are marked, the cartridge must be retired.

There is a demonstration/presentation explaining how to use the Plasmon UDO drive cleaning cartridge at <http://www.astiusa.com>.

UDO Media

The Plasmon Gx24 – Gx174 libraries use UDO media with either 30GB or 60GB capacity, depending on UDO drive type. These are available in both true Write Once, Rewritable, and Compliant Write Once media types. Compliant Write Once media provides for selective data destruction for security purposes.

UDO media is not compatible with MO drives, and MO media is not compatible with UDO drives. The media transport assembly (MTA) in the library identifies the media type and does not try to insert incorrect media into a drive.

Data is written to and read from a disk enclosed within a carrier cartridge. If the library has the optional barcode reader, a barcode label on the cartridge identifies it to the library system software.



Figure 2. UDO Media

Write Protecting UDO Media

To write protect one side of the media, slide the tab on that side in the direction of the protect arrow as shown in the figure below. There is a write protect tab on each side of the disk. When a side is protected, the Write Protect window is open.

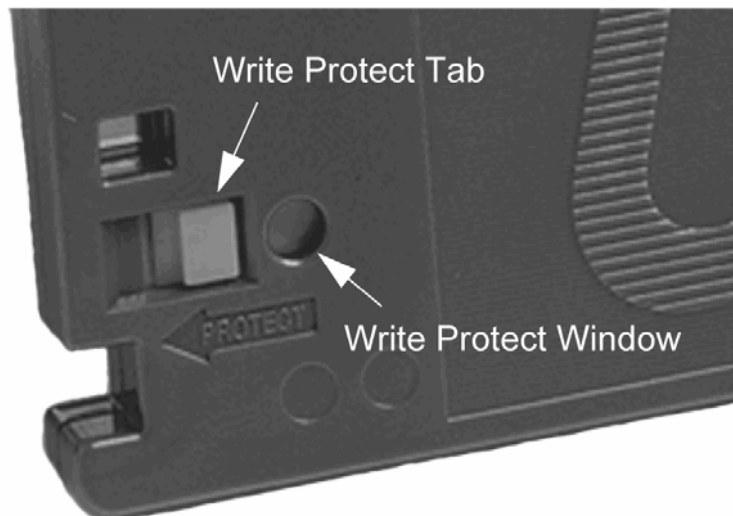

Figure 3. Write Protecting UDO Media

Barcode Label

For more detailed information about barcode data and how it is read, refer to the Gx Libraries SCSI Reference Manual.

The optional barcode scanner supports Code 39 barcode symbology, and the Biased-Double Barcode (Type 2) label format.

Never place a label anywhere on the media except in the specified “label area”, as this may interfere with the proper handling of the media in the drive or the media transport assembly!

CAUTION



Do not write on, cover, or obscure the barcodes on a media. Doing so may cause the system to malfunction.

Biased-Double Barcode (Type 2) is the only appropriate label format for Gx libraries.

The barcode must be approximately centered along the outside edge of the media so the alphanumeric characters in the center read properly when the A side of the media is up. This barcode configuration is done with two barcodes – one on each end of the label. The Label is 4.9” (12.5 cm) long with seven characters. Bar codes of this type are available from Tri-Optic (www.tri-optic.com), part number 1801-47PA.



Figure 4. Type 2 Barcode Label Format and Placement

NOTE

When ordering barcode labels make sure to get a unique sequence of numbers.

Media Care and Handling

To maintain maximum reliability, the operator should take the time to inspect each media cartridge before use, and whenever it is removed from the library.

CAUTION



Always condition the media to the normal operating temperature of the room before using.

Improper handling or an inappropriate environment can damage the media. To ensure continued reliability:

- When media is loaded into the library, or when handling media, ensure that the cartridge case is clean. Dirty media cartridges can cause failures in loading or loss of data. If a cartridge case is dirty, wipe with a lint free cloth.
- Do not carry media loosely (for example, in a box or basket). Media should be carefully and securely packed for transport.
- Do not load damaged media into a drive or library. Damaged media can interfere with read/write reliability.
- Never touch the disk. Opening the cartridge door and touching the disk may interfere with read/write reliability.
- Do not expose the media to moisture or direct sunlight.
- Do not expose the media to excessive heat (the allowable temperature range is 5 to 55°C).

Major Hardware Components

The following figures show the locations of major library hardware components of all three chassis sizes. In these figures the protective panels and outer skin of the library are removed.

A brief description of these components appears at the end of this section.

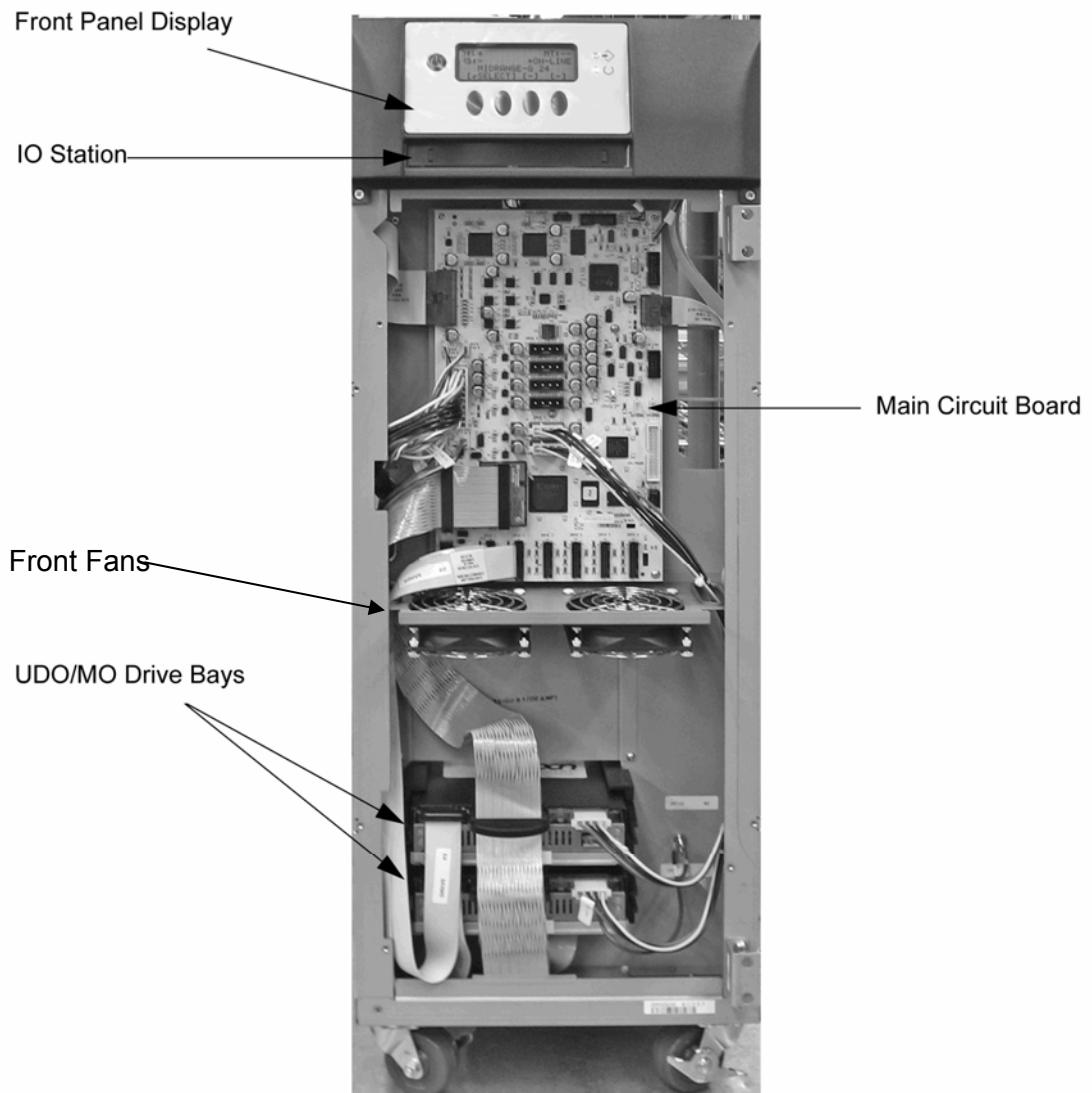

Figure 5. Gx24, 32 Series Libraries, Single Column, Front View

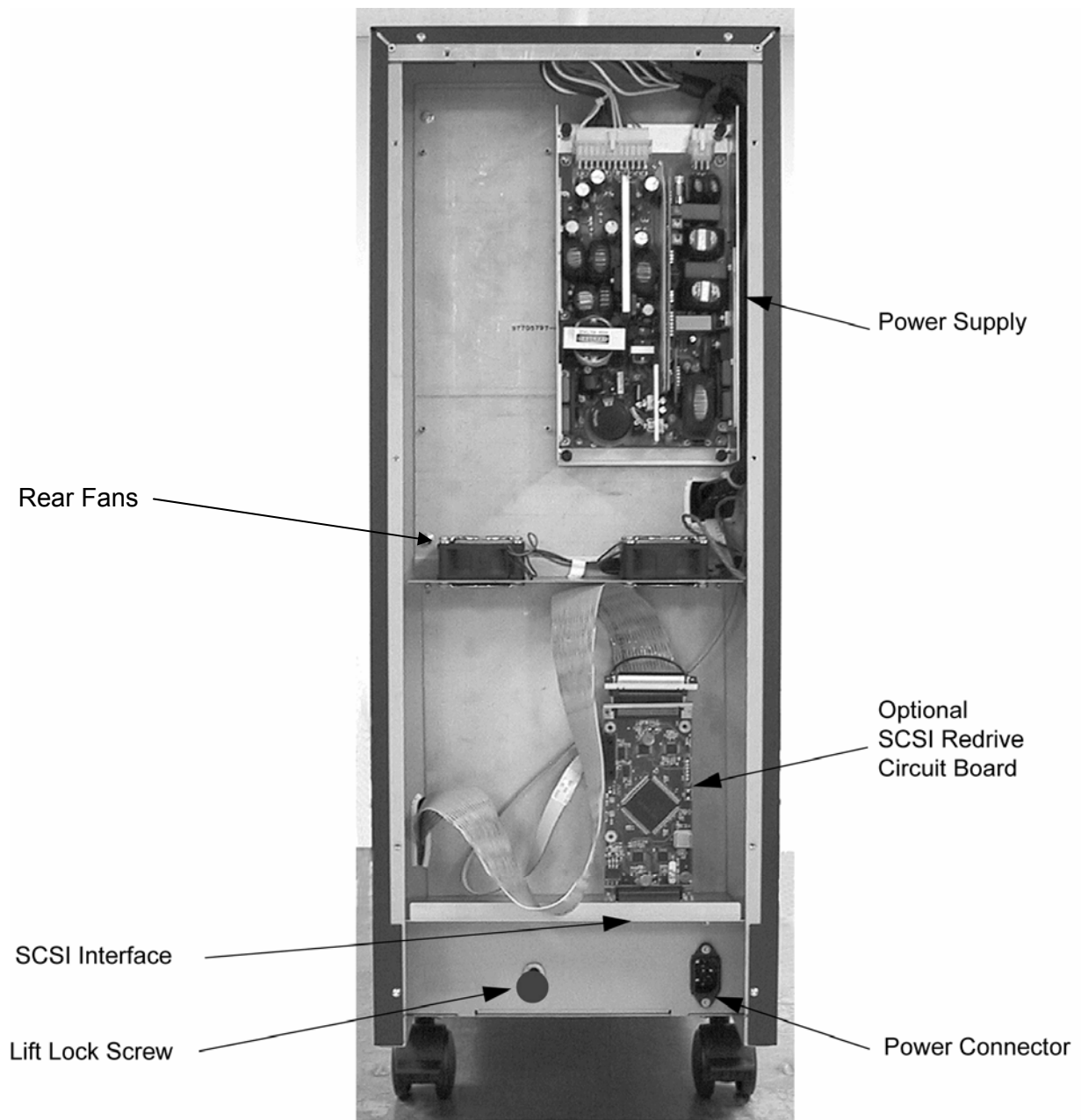

Figure 6. Gx24, 32 Series Libraries, Single Column, Rear View

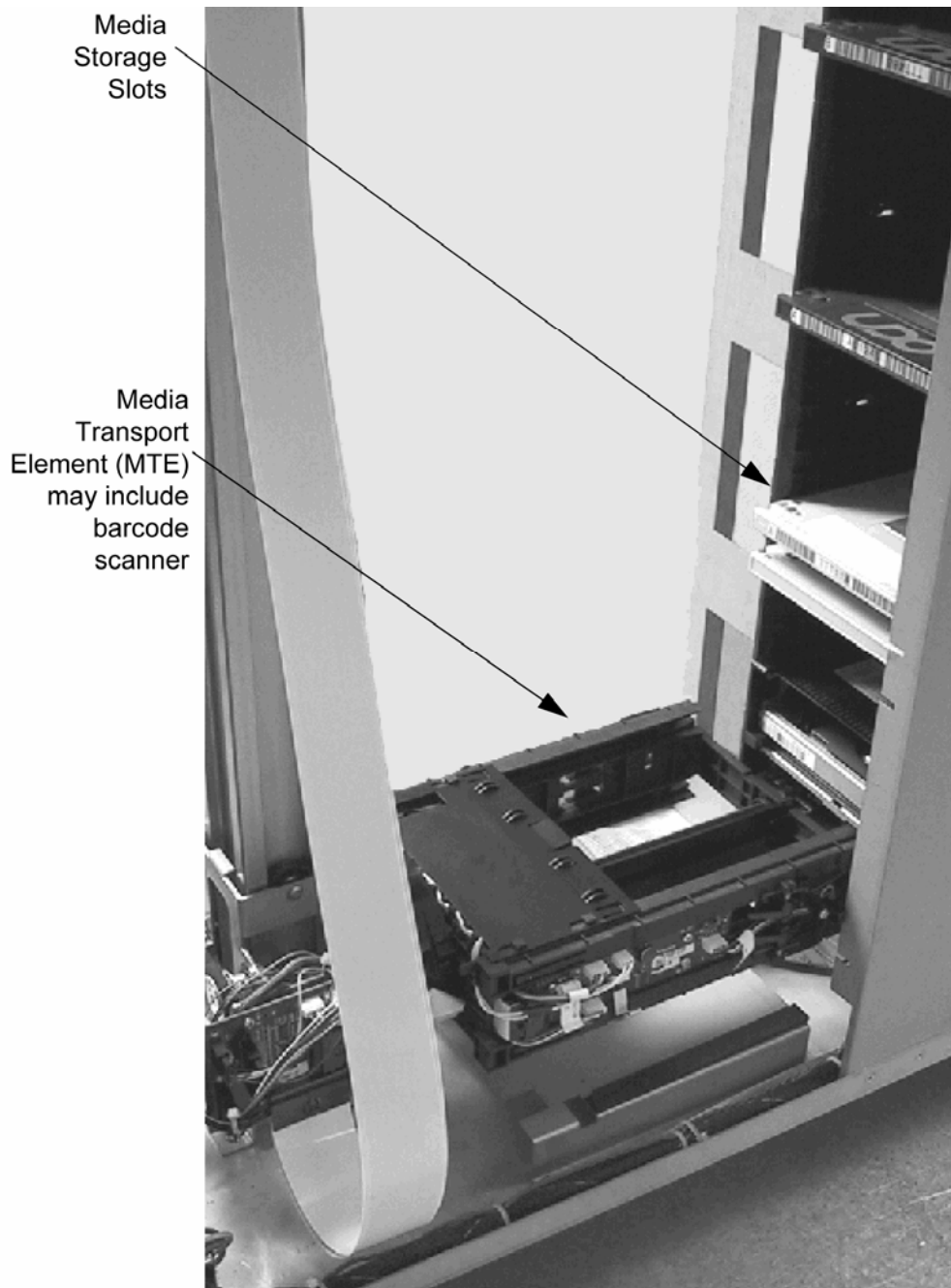

Figure 7. Gx24, 32 Series Libraries, Single Column, Inside View

Front Panel Display

IO Station

Main Circuit Board

Front Fans

UDO/MO Drive Bays
(configured for two or four drives)

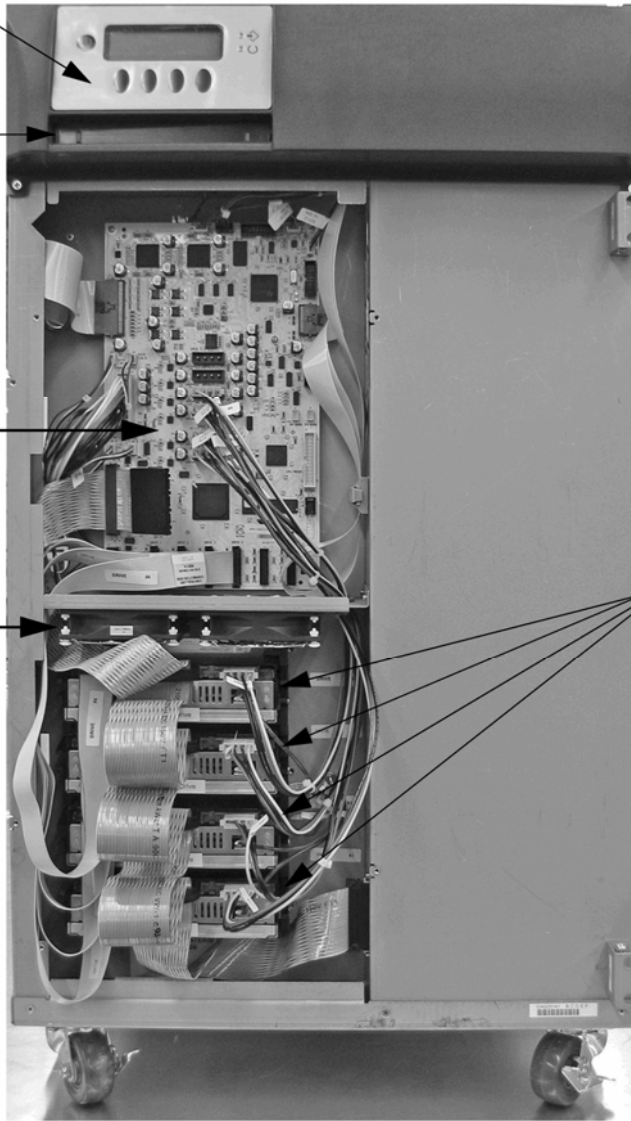

Figure 8. Gx20, 40, 60, 72, 80 Series Libraries, Dual Column, Front View

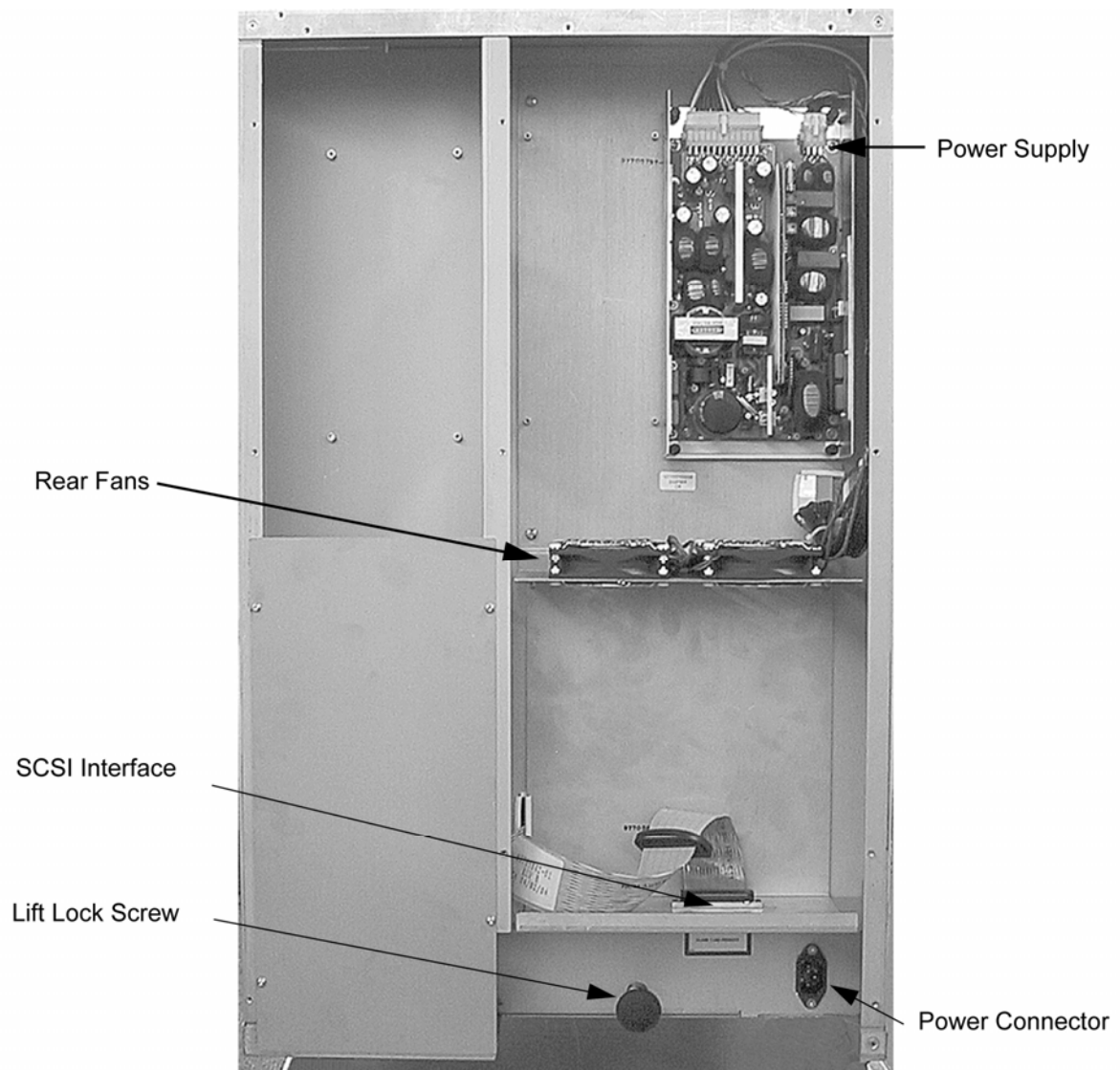

Figure 9. Gx20, 40, 60, 72, 80 Series Libraries, Dual Column, Rear View

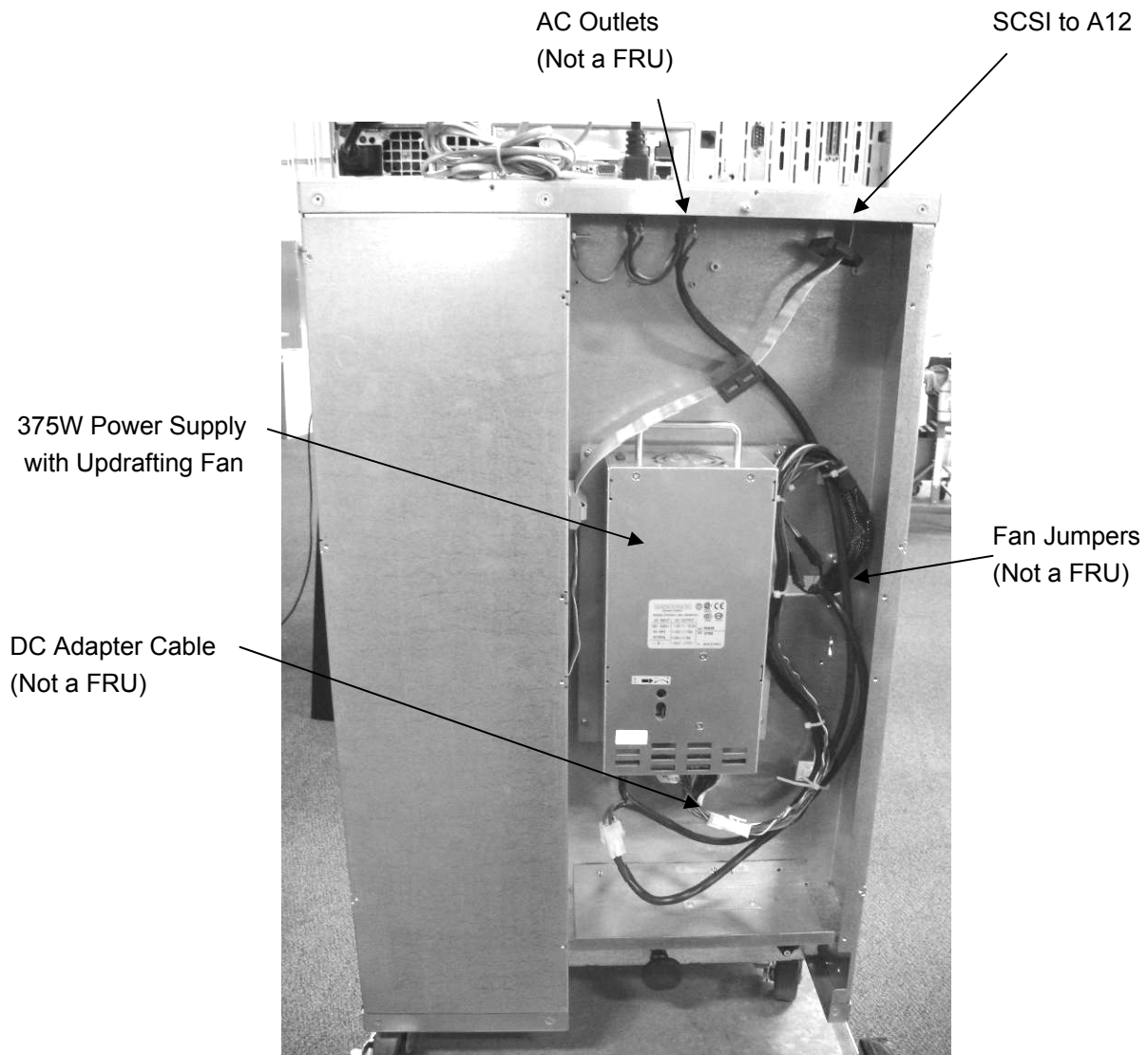

Figure 10. Elite AA20, 40, 60, 72, 80 Series Libraries, Rear View

NOTE

Note: Elite AA80 series libraries with E12 SMS differ from AA80 libraries with A12 SMS in that they use the larger 375W power supply with integral fans, thereby eliminating the need for a rear dual fan assembly. Fan shorting jumpers must be installed to terminate the unused cable connectors.

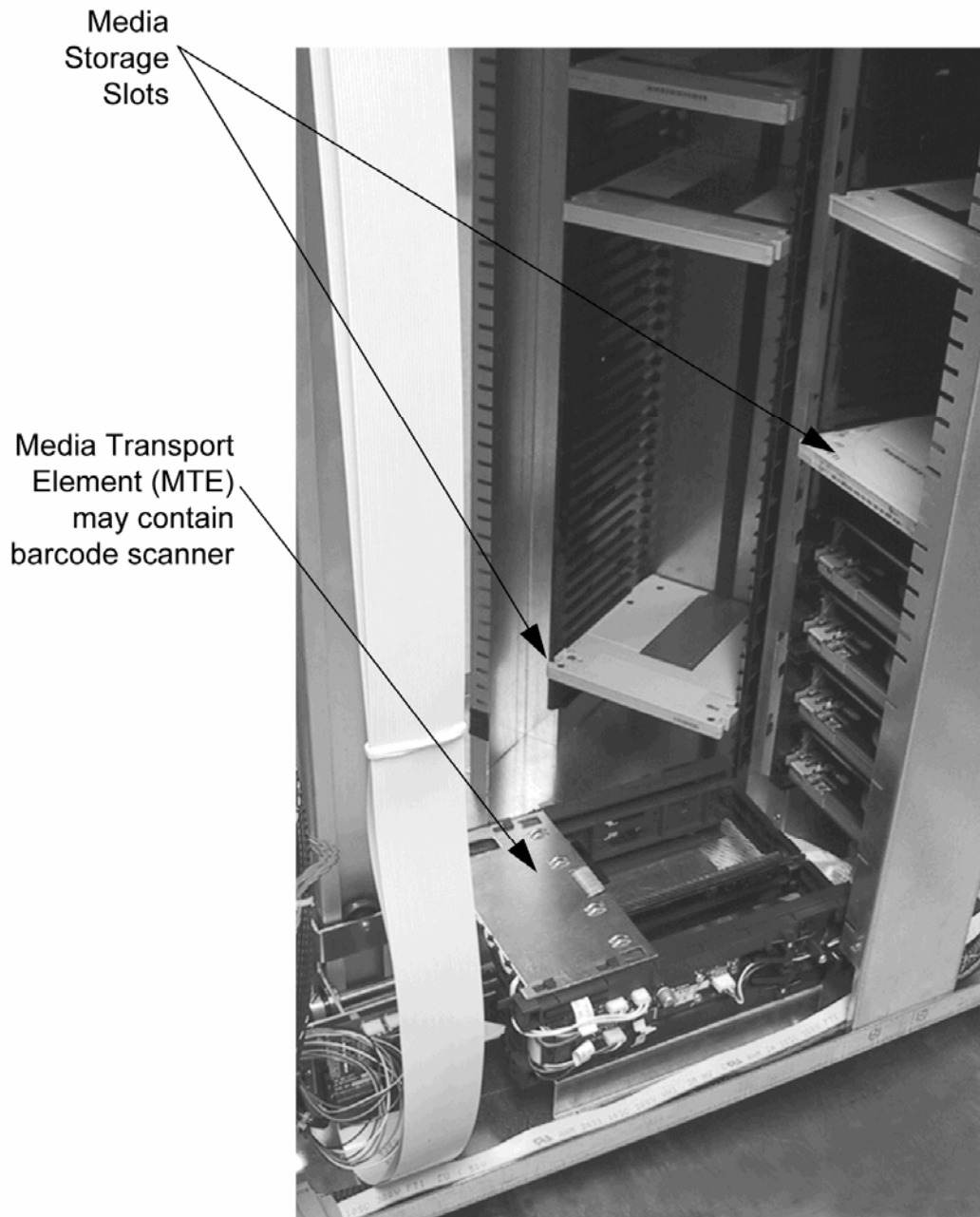

Figure 11. Gx20, 40, 60, 72, 80 Series Libraries, Dual Column, Inside View

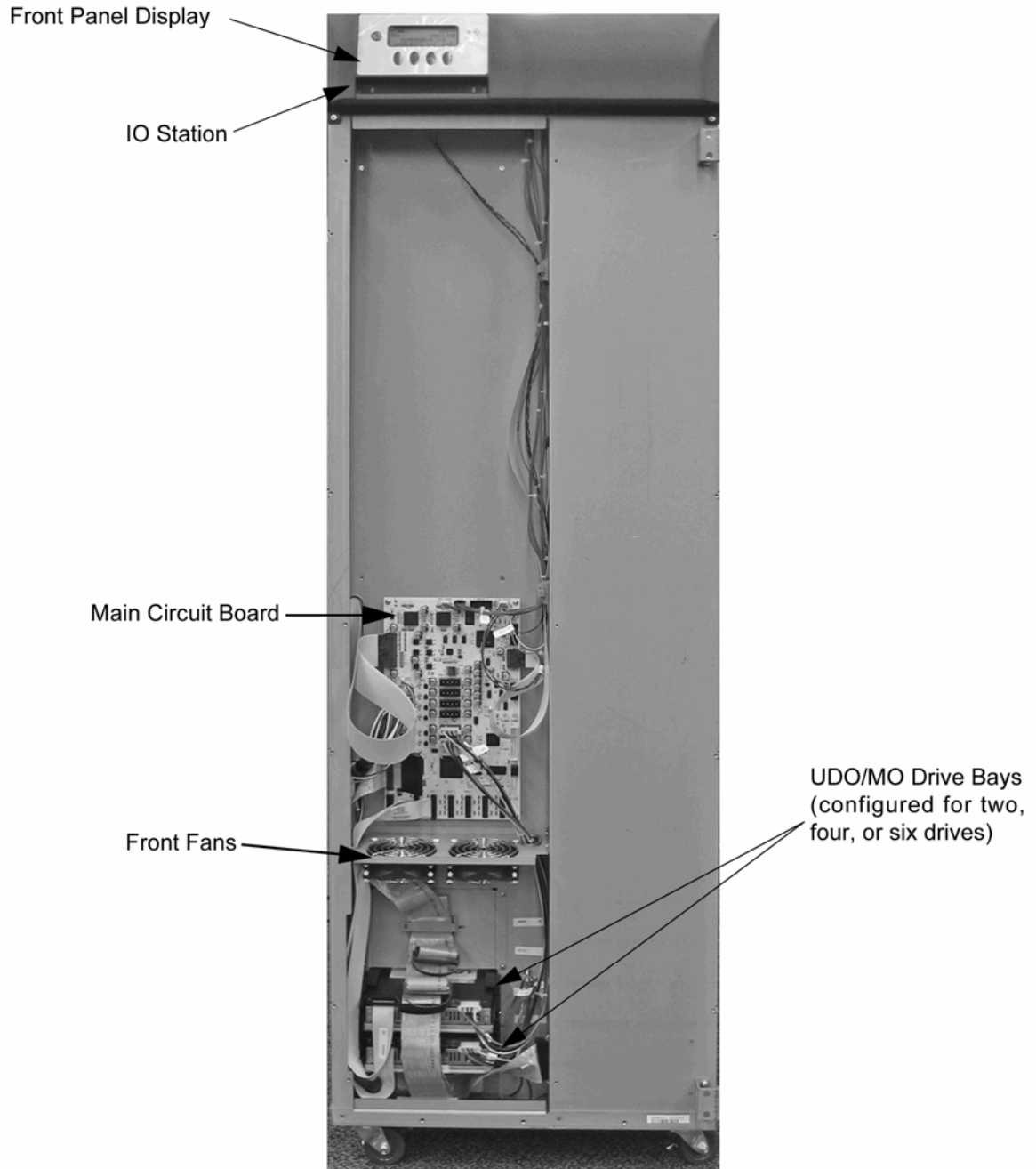

Figure 12. Gx100, 120, 134, 140, 158, 166, 174 Series Libraries, Dual Column, Front View

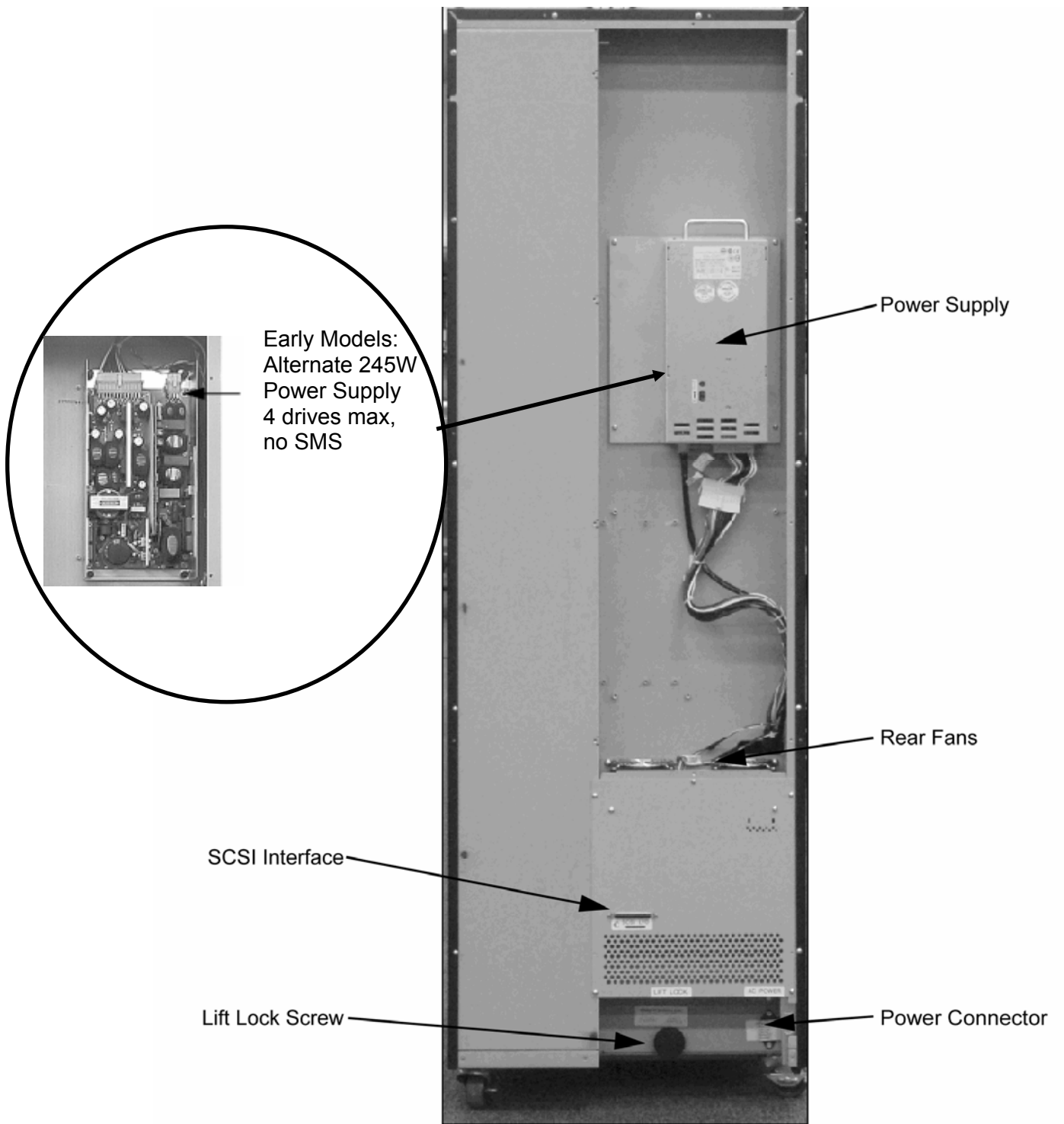

Figure 13. Gx100, 120, 134, 140, 158, 166, 174 Series Libraries, Dual Column, Rear View

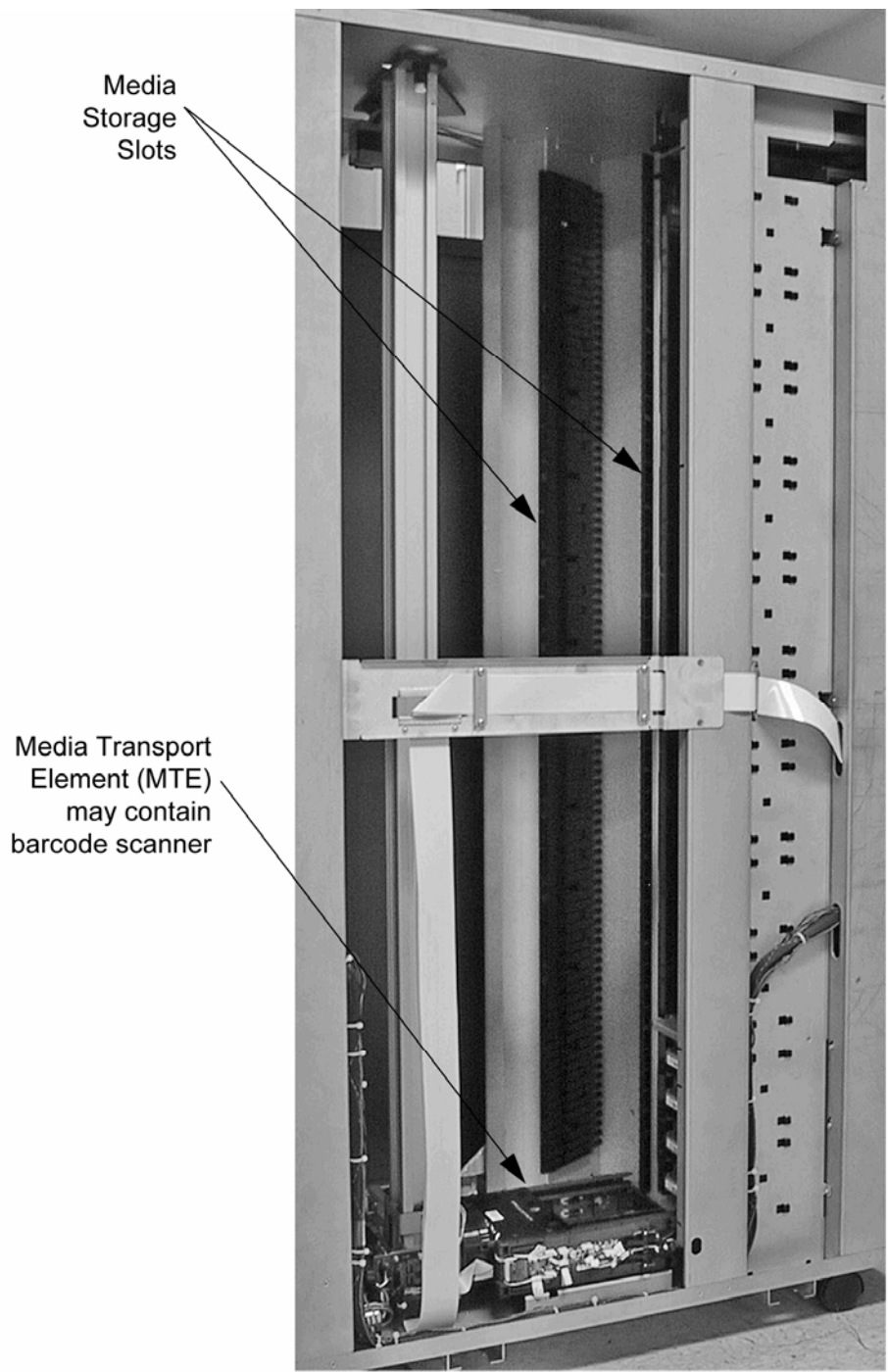

Figure 14. Gx100, 120, 134, 140, 158, 166, 174 Series Libraries, Inside View

Front Panel Display

The front panel display consists of the keypad and display window, which provide the operator interface to the system. It contains the library power on/off switch and is used to display tests, modes, error codes and other user related messages.

IO Station

The automated mailslot, or I/O station, is capable of importing and exporting single media while the library is on-line.

Drives

The optical drives in the library allow reading and writing of data. They are fully tested to work with the library. These libraries can use both UDO30 and UDO60 drives, MO drives, or a mix of these if the driver software supports this feature.

SCSI Interface

The SCSI interface provides for connection between the library and host computer. The interface to the library is an LVD SCSI bus, using shielded 68 pin high-density connectors.

Lift Lock Screw

The lift lock screw secures the MTA during shipment or whenever moving the library.

Power Connector

The power connector is used to supply power to the library.

Media Store

The media store holds each media in place. It consists of vertically arranged slots with plastic grooved guide panels that hold each media.

Media Transport Assembly (MTA)

The media transport assembly moves media between storage locations and drives or the IO station, and consists of the dual picker and flip assembly.

Optional SCSI Redrive Circuit Board

On Gx libraries the optional SCSI Redrive circuit board shown in Figure 14 isolates the internal SCSI bus from the external SCSI bus, and communicates between the two. This allows maximum external cable lengths for library connectivity. If MO drives are present, this option is required. Figure 14 shows the location of the SCSI Redrive circuit board in the Gx80 and Gx174 Series libraries. Figure 6 on page 20 shows its location in the Gx24 and Gx32 libraries.



Figure 15. SCSI Redrive Circuit Board

Optional SMS

Storage Management System options include the A2 Internal Archive Controller, the A12, and the Elite E12. Refer to Chapter 4 on page 85.

CHAPTER 2

LIBRARY INSTALLATION

Getting Started

This chapter provides a guide to installing the Plasmon Gx libraries and the procedures necessary to get a library on-line.

Unpacking the Library

Save all packaging material in case it is ever necessary to ship the library. Read the section in this chapter describing the Lift Lock Screw before powering on the Library.

Library Position

Position the library in a location that allows the front door to open completely without obstruction. Allow a minimum three-inch clearance at the back for ventilation. Unless the library is rack mounted, install the stabilizers following instructions provided later in this chapter. The library functions properly when sitting on a floor with no more than a 3/8" (0.9525 cm) rise or fall over a 36" (91.44 cm) run. Plan for the AC power cord set length to reach the UPS power source outlet. The library includes a 7.5ft (2.3m) cord set. (See Appendix C.)

To mount the Gx24-32 and Gx20-80 Series libraries in a standard 19" rack, refer to the Rack Mount Guidelines section later in this chapter before proceeding. Skip the Library Stabilizers section, as stabilizers are not required in a rack mount. The tall models do not rack mount.

Library Environment

To ensure long-term reliability, operate the library only between 10° to 32°C (50° to 90°F) and 10% to 90% relative Humidity. The media and drives require a clean environment. Excessive dust and dirt can lead to data loss, and increase service calls.

External Power Requirements

The library requires an earth grounded power source with 100 to 253 VAC (the library power supply is universal) at 50 to 60 Hz, and 15 A branch circuit protection.

CAUTION



A UPS or a facility backup genset branch is required to prevent the possibility of robotic errors during a pick or put operation if AC power is lost. (See Specifications in Appendix C.)

Library Stabilizers

All Gx and AA Series systems ship with stabilizers for each unit. The stabilizers prevent the library from tipping due to accidental force.

CAUTION



In order to comply with safety standards, the stabilizers must be installed (does not apply to rack mounted libraries).

Installing the Leg Stabilizers – All Models

Included in the stabilizer kit are:

- Four side stabilizers

To install the four side stabilizers (two on each side):

1. Insert the stabilizers into the channels on the bottom of the library chassis as shown in the picture below. Push them until they snap into place.

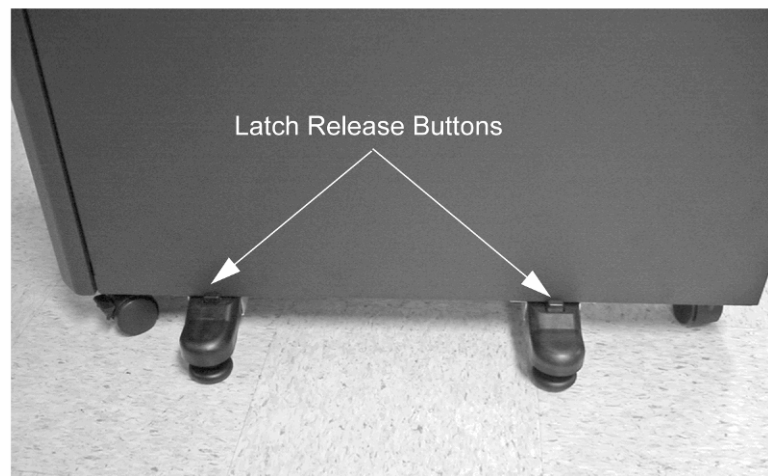

Figure 16. Gx20 – Gx80 Series Side Stabilizers

2. To remove the stabilizers, depress the latch release buttons and pull outwards.

Installing the Gx100 – 174 and AA100 - 174 Series Front Stabilizers

Included in the stabilizer kit are:

- Four side stabilizers
- One front stabilizer
- Three 8-32 Phillips head screws

To install the front stabilizer:

1. Open the front door of the library
2. Attach the front stabilizer to the bottom edge of the library chassis using the three 8-32 Phillips head screws as shown in the picture below.

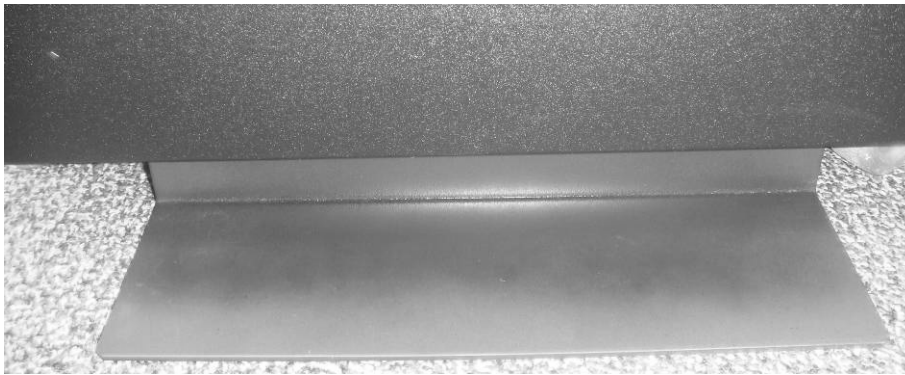

Note: Gx Elite AA174 Libraries with E12 SMS units require the larger front foot stabilizer shown below.

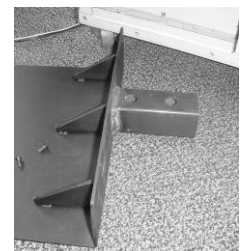

Figure 17. Gx100 – 174, AA100-174 and Elite AA100-174 Series Front Stabilizer

Lift Lock Screw

All models are shipped with MTA locked in place by the lift lock screw. The lift lock screw is located at the back of the library near the bottom. Leave the lift lock screw engaged until the library is stable and in its final position. Always re-engage the lift lock screw to move the library.

CAUTION



Before applying power to the library the lift lock screw must be turned counterclockwise until the spring pops it outward (the screw remains in place). Failure to do so may seriously damage the library.



Figure 18. Lift Lock and Power Connector for Gx Libraries

Power Connection

Route the power cable to the power connector located at the lower right in the back of the library.

The power cable can be plugged into a standard 120 volt to 240-volt wall outlet. The library system uses a universal power supply.

CAUTION



THE POWER SUPPLY CORD IS USED AS THE MAIN DISCONNECT DEVICE. ENSURE THAT THE SERVICE OUTLET IS LOCATED NEAR THE EQUIPMENT AND IS EASILY ACCESSIBLE.

Do not use an extension cord. In the event that an emergency power cutoff is required, pull the plug from the AC socket. Data loss may result. Refer to the appendix for all cord and UPS requirements.

Power Cord Retainer

A power cord retainer is provided for installations where there is a chance the cord could be accidentally disconnected from the library. Follow these steps to install the retainer:

1. Remove the two 6-32 flat head Phillips screws mounting the AC power receptacle at the back of the library.

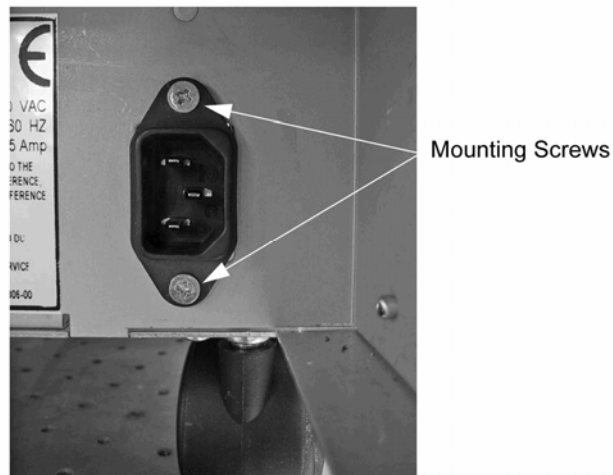

Figure 19. Installing the Power Cord Retainer

2. Place the retainer as shown and attach with the two 6-32 pan head Phillips screws provided with the retainer. Do not tighten these two screws until the clamp is adjusted to the plug.

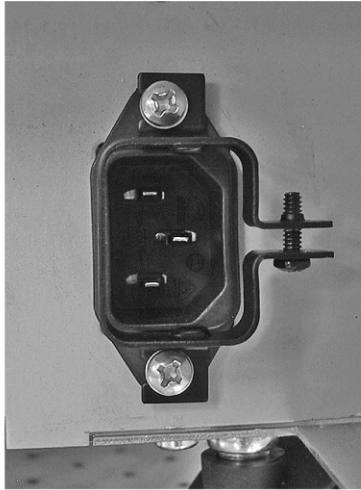

Figure 20. Installing the Power Cord Retainer

3. Insert the power cord into the AC receptacle. Secure the cord to the library by tightening the retainer clamp with a short Phillips screw driver. Now completely tighten the two mounting screws.

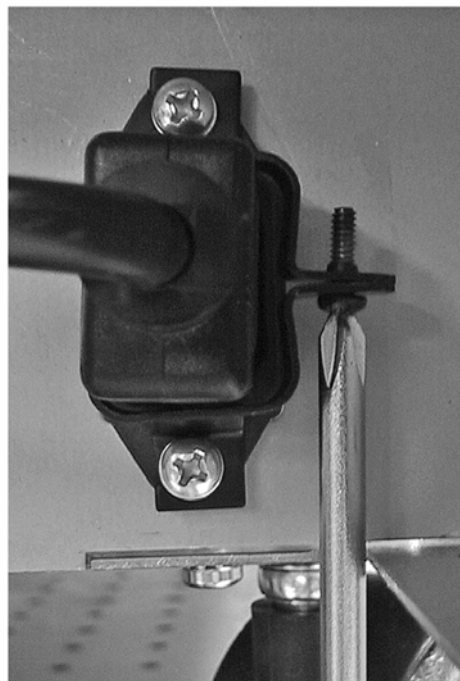

Figure 21. Installing the Power Cord Retainer

Gx SCSI Connection

Stand-alone libraries (non-AA) require a host computer with a dedicated Ultra 320 LVD SCSI host bus adapter. Note that all SCSI termination is provided internally. See SCSI Bus Information, Appendix B, for cable requirements. For AA model connections, see Chapter 4.

With the library powered off, install the following SCSI cables as needed.

External Host SCSI to Library

Route the SCSI cable to the LVD HD68 connector located at mid height on the back panel of the library. Gently secure the thumbscrews.

Internal A12 SMS SCSI

Route the 1 ft internal SCSI cable from the SMS slot number 3 HD68 SCSI card connector to the upper rear HD68 SCSI bulkhead connector of the library. Gently secure the thumbscrews.

Internal E12 SMS SCSI

Route the 1 ft internal SCSI cable from the SMS slot number 2 VDHCI SCSI card connector to the upper rear HD68 SCSI bulkhead connector of the library. Gently secure the thumbscrews.

External SMS SCSI to Optional Extension Library

An optional dual SCSI interface kit can be supplied for the AA80/174-A12 series and the Elite AA80/174 E12 series to support a second extension library unit. Refer to the orderable option kits.

Loading Media

Use only Alliance approved UDO or MO media in the library.

Bulk Loading Media

Alliance recommends manual bulk loading of media during the initial setup. Other software management systems must be checked to ensure support for initial bulk loading. Refer to the library management software documentation for the required procedures. *Note that on Plasmon AA SMS systems that have been initialized, the only supported method of loading additional media is through the IO Station mailslot.*

To bulk load media, the library must be powered down with the power cord sets unplugged. Remove the painted sheet metal side skin (left side, facing the front of the library) and manually insert media into the storage slots. After loading, follow the initial power up procedure. The library must be initialized so the media is recognized. At the front panel display menu, select Set Up Library>Offline Operations>Scan Elements (see *Chapter 3 Menu System*).

When bulk loading media, refer to the slot diagrams on the following pages to ensure media is not loaded into the Utility Slots. These two slots must be left empty for library operation.

Care must be taken while bulk loading to avoid damage to the library's internal mechanisms, sensors, and wiring.

WARNING



On AA systems, follow the instructions in Chapter 4 to turn off the library. Then, unplug the power cord before removing or replacing components. Failure to do so may result in possible electrical shock, damage to the library, and/or data loss.

CAUTION



Plasmon libraries contain sensitive electrical components. To avoid ESD related damage, ensure proper grounding and anti-static measures are in place (for example, wrist straps and anti-static mats).

IO Station Media Loading

After the initial bulk load of media, Alliance recommends loading media into the library using library management software and the automated IO station. This method insures proper recognition of the media by the library. Manual loading through the IO Station mailslot is also the only supported method of loading an AA SMS system after it has been initialized.



Figure 22. . Loading Media Using the IO Station

Initial Power On: Non-AA Library Systems

Press the power switch located on the front panel display to turn the library on (switch must be pressed twice to turn the library off). For AA models, refer to Chapter 4 instructions.

!!CAUTION!!

If the system is an AA SMS model, do not power-down by the front panel!! Always use the AA power-down procedure as detailed in Chapter 4.

The library takes a few minutes to initialize. When the process is completed, the front panel display indicates that the library is on-line and ready for operation. The Gx library model (MIDRANGE-G) and the number of available media slots (166 in the example below) will also be indicated.

In the event the library has licensed media slots (all Gx except Gx24-32 Series and Archive Appliance), it is possible for the number of available media slots to be zero. In this case, Alliance Technical Support must be contacted to obtain a license key to enable the library. To obtain a key, the library eleven digit serial number and number of slots to be licensed must be provided. Once the license key has been obtained, follow the instructions in Chapter 3 Menu System to enter the key through the front panel and enable the library. The license key may also be entered via the SCSI interface by the service technician installing the library or replacing a main controller PCA.



Figure 23. Front Panel Display at Power On

Host Computer

It may be necessary to reboot the host computer to recognize the library as the new device. Some modifications to the host hardware or operating system may also be necessary. These modifications may include patches, driver updates, or modifications to the configuration files. Please consult the host hardware or operating system documentation to see if any of these modifications are necessary. Then, if necessary, contact the hardware or software vendor for the appropriate patch or update.

Identifying Storage Slots

Inside each library is a diagram of the slot numbering scheme for that particular model. The following diagrams also show this information.

NOTE

The Utility Slots are not for media storage. They are used by the MTA to manipulate media.

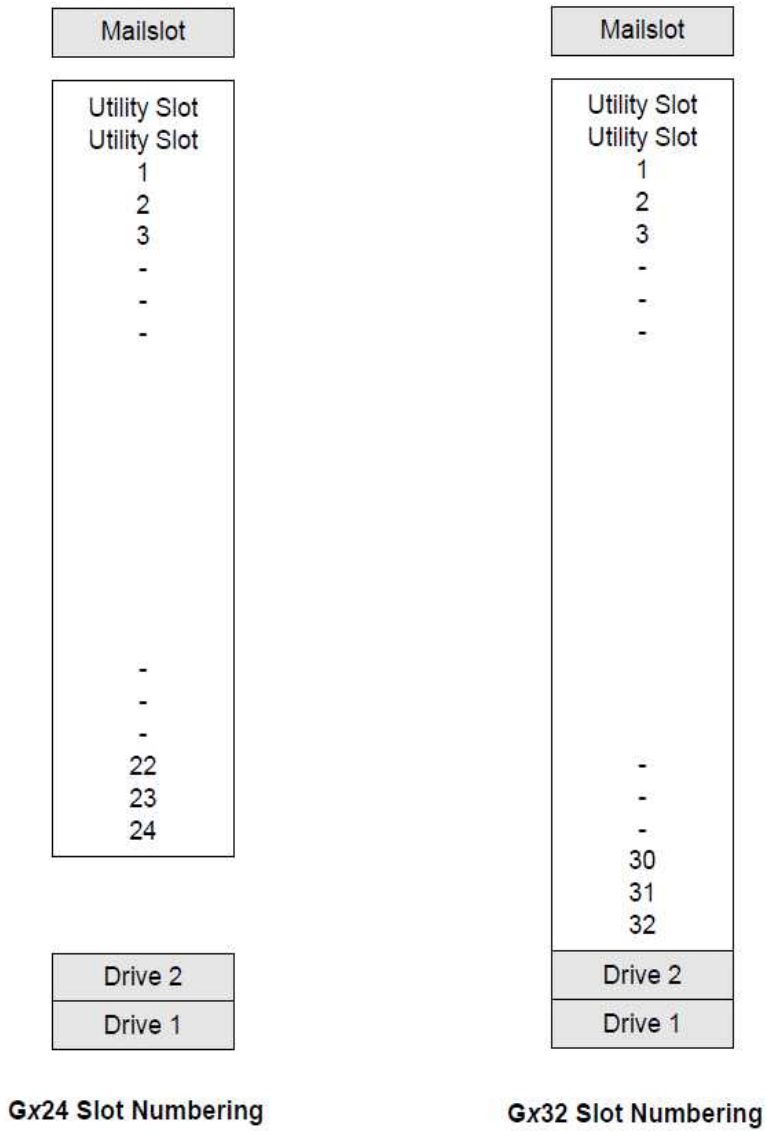
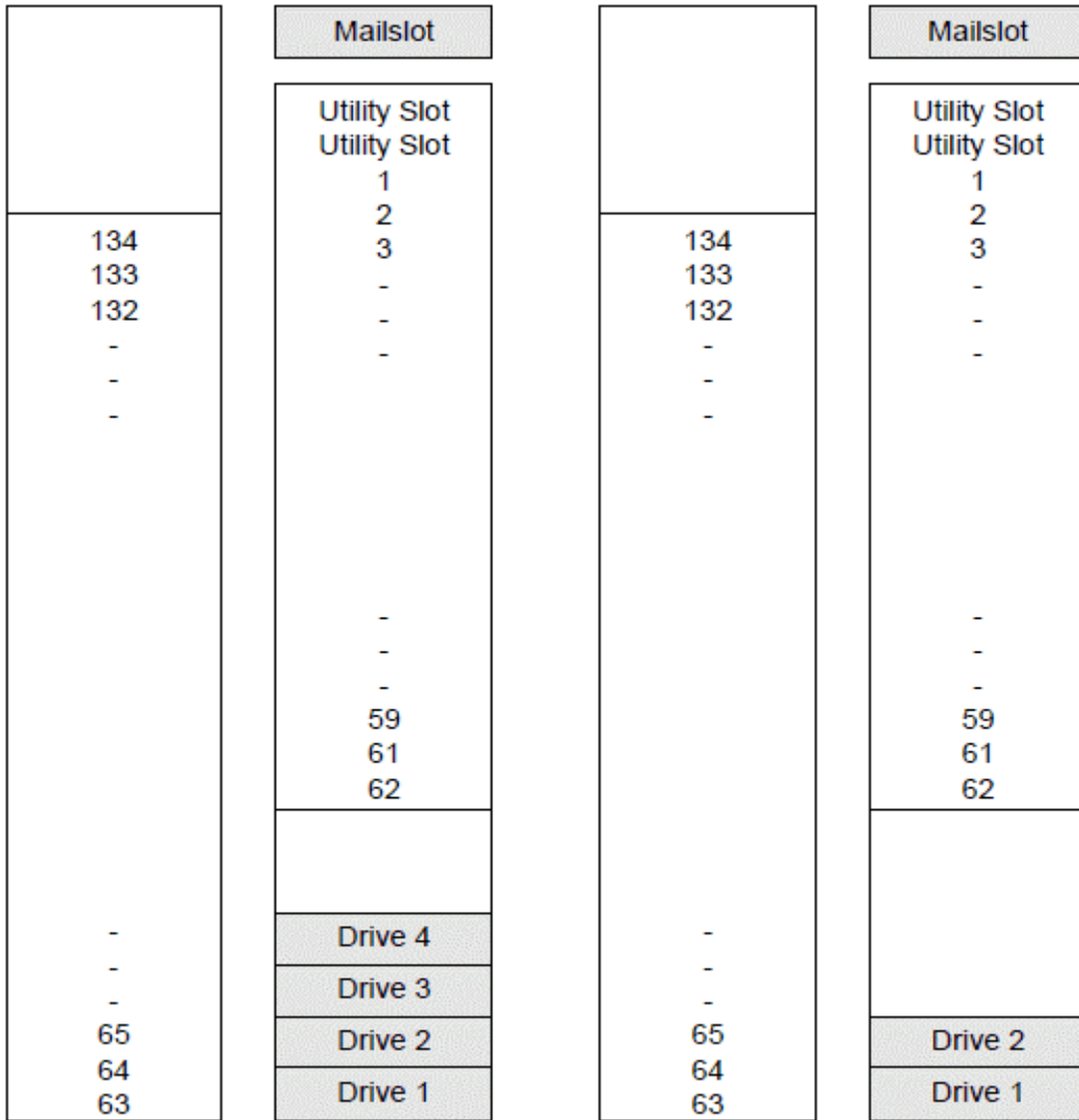

Figure 24. Gx24 – Gx32 Slot Diagram



Gx134 (4 drives) Slot Map

Gx134 (2 drives) Slot Map

Figure 26. Gx134 Slot Diagram

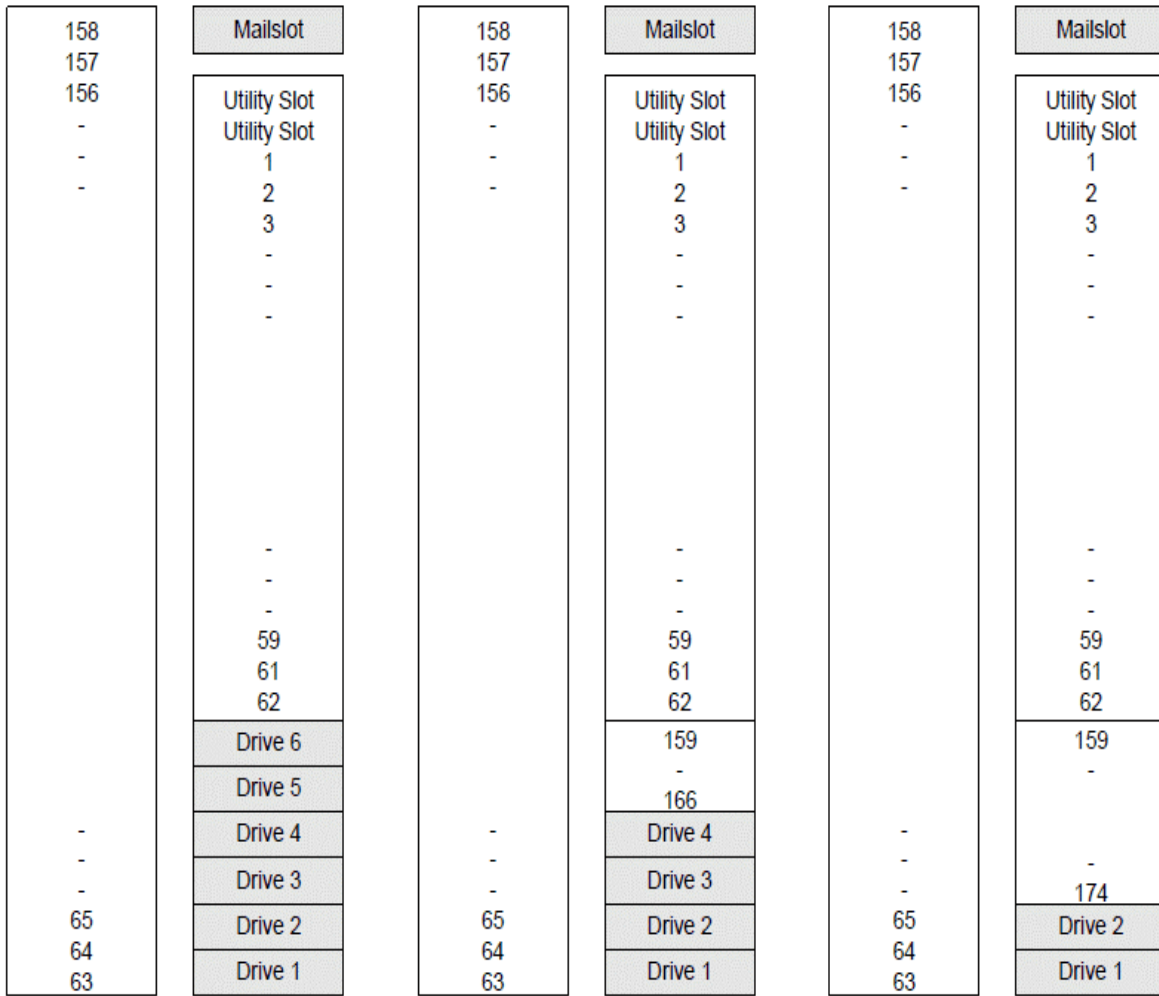

Gx174 (6 drives) Slot Map

Gx174 (4 drives) Slot Map

Gx174 (2 drives) Slot Map

Figure 27. Gx174 Slot Diagram

Rack Mount Guidelines

This section provides information for mounting Gx24 - 174 or AA16 – AA174 (A12 and Elite) libraries into an Electronics Industry Association (EAI 310-D) standard 19" (48.3 cm) rack. The standard 19" rack must have between 24" and 40" (61 - 101.6 cm) between front and back mounting columns to provide sufficient depth for the library. The library and rack mounting hardware combined requires 19 units minimum of rack space. One rack unit (1U) equals 1.75" (4.445 cm).

Table 3. Library Rack Size Chart

MODEL	Gx32/AA32	Gx80/AA80	Gx174/AA174	AA80A12	AA174A12
1 st Chassis Height	16U	16U	30U	18U	32U
Rackmount Shelf	2U	2U	2U	2U	2U
Stabilizer	1U	1U	1U	1U	1U
Total	19U	19U	33U	21U	35U
2 nd Chassis Height	16U	16U	na	16U (Gx80e)	na
Rackmount Shelf	2U	2U	na	2U	na
Total	37U	37U	na	39U	na

If the unit is installed in a closed or multi-rack assembly, refer to the following guidelines:

- The operation temperature of the rack environment may be greater than the ambient temperature.
Be sure to install the unit in an environment that is compatible with the maximum rated ambient temperature. (See *Appendix A Specifications*.)
- When mounting the equipment in the rack, make sure mechanical installation is level to avoid a hazardous condition. The rack must be specified to safely support the combined weight of all equipment.
 - Do not mount library more than 37" (94 cm) off the floor. Alliance recommends mounting in the lowest position. Libraries mounted no more than 14" (35.6 cm) off the floor can be safely installed by a single Field Engineer as described in this instruction. An extension or secondary library installation requires two people.
 - The rack enclosure itself must weigh at least 200 lbs (90.7 kg), unloaded, for a safe installation into a non-anchored cabinet with front extended Alliance stabilizers.
 - In the pulled out service position, the mounting shelf can support the library. The combined maximum weight is 250 lbs (113.4 kg) on a 24 inch (61 cm) cantilever arm. Cabinets must be supported with the extended Alliance supplied stabilizer assemblies before either the mid or low shelf is pulled out into the service position.

CAUTION: SERVICE POSITION



Never extend both library shelves at the same time from their fully seated position.

Never extend either the low or mid mounted shelf without the Alliance stabilizers pulled forward.

WARNING: LIFTING



Use safe lifting procedures when installing the library on the rack mount shelf. The libraries weigh up to 110 lbs (50 kg) empty and stripped down for installation as shown in this instruction.

Required Tools

The following tools are required to install the rack mount assembly:

- #1 and #2 Phillips head screwdrivers
- 7/16" wrench (box end preferred)
- Pliers

Rack Mount Kit

Part Number	Description
920-101913-00	Combined Kit with Shelf and Stabilizer
920-101805-00	Rack Mount Shelf Kit only
310-101802-00	Shelf
490-101801-00	Shelf Slides (2)
310-101803-00	Front Mounting Brackets (2)
310-101804-00	Back Mounting Brackets (2)
400-101904-00	Clip-on Cage Nuts, 1/4-20 (4)
400-101905-00	Phillips Pan Head Screws, 1/4-20 x 5/8 (12)
400-101906-00	Phillips Pan Head Screws, 1/4-20 x 3/8 (6)
400-101686-00	Phillips Pan Head Screws, 10-32 x 500, LW (8)
400-101201-00	Phillips Pan Head Screws, 8-32 x 3/8 (10)
97707512-00	S-Style Clip-on-Nuts, 10-32 (4)
490-101-928-00	Shelf Handle
390-102438-00	C Clamps (2)
920-101834-00	Rack Mount Stabilizer Kit only
370-101833-00	Stabilizer Frame
310-101831-00	Back Mounting Brackets (2)
370-101832-00	Stabilizer Legs (2)
400-101907-00	Leveling Feet (2)
400-101909-00	Carriage Bolts, 1/4-20 x 2 (4)
400-101908-00	Flange Nuts, 1/4-20 (4)
400-101686-00	Phillips Pan Head Screws, 10-32 x 500, LW (8)
97707512-00	S-style Clip-on Nuts, 10-32 (12)
920-101693-00	Filler Panel Kit (for Gx24 – Gx32 or AA32)
310-101681-00	Filler Panel
400-101686-00	Phillips Pan Head Screws, 10-32 x 500, LW (4)
400-101680-00	Screws, 6-32 x 250, undercut (2)

Table 4. Rack Mount Kit Part Numbers/Descriptions

Rack Mount Installation

In this rack mount, the library attaches to a shelf, which is mounted to the vertical rails of the rack. To enable library service access, the shelf pulls out from the front of the rack. If the rack is not self-stabilized, a stabilizer must be installed below the library shelf to make this possible.

There are three stages to this rack mount installation:

- Stabilizer Installation (if rack is not self-stabilized)
- Library Shelf Installation
- Library Installation



WARNING



To safely pull the shelf out to service the library, as shown above, the rack mount cabinet must either be secured to the floor or cabinet stabilization must be installed or engaged. Failure to do so could result in injury. Alliance is not responsible for injury due to an unstable cabinet.

Stabilizer Installation

The rack mount stabilizer mechanism is required, unless the rack is self-stabilized, so the library shelf can be safely pulled out of the rack for servicing the library. Mount the stabilizer into the lowest 1U position in the rack. The stabilizer feet adjust between 3 ½" and 6 ¼" (8.9 – 15.9 cm) from the bottom of the mounting rails.

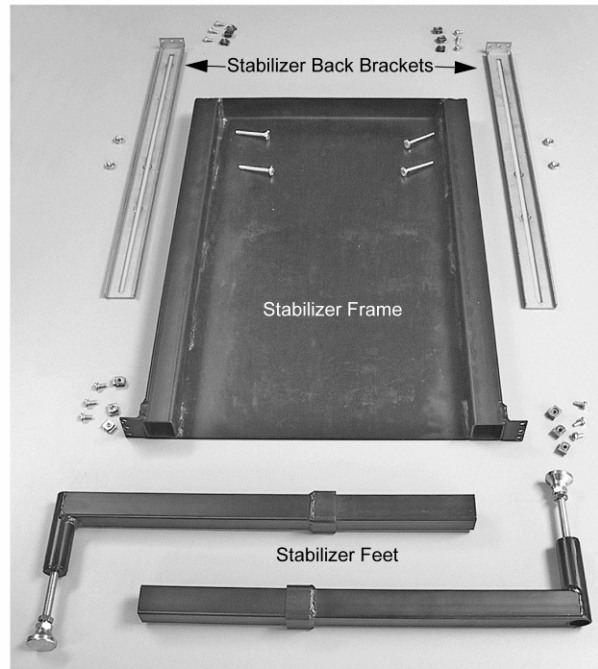

1. First, clip three 10-32 s-nuts into the lowest 1U position on all four rack rails.

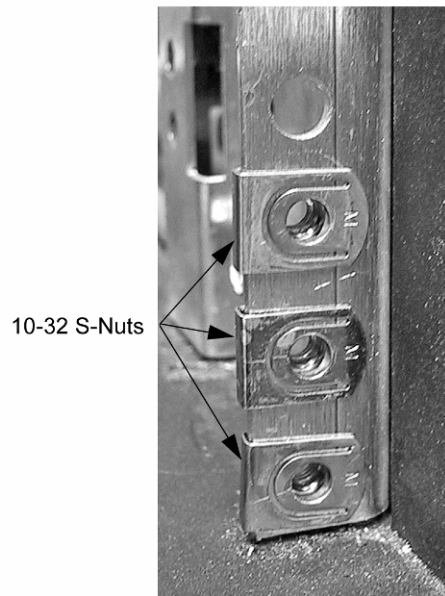

2. Mount the stabilizer back brackets (see rear view picture below) to the rack using three 10-32 x 1/2 Phillips pan head screws with washers for each bracket as shown below.



Rear View

3. Mount the stabilizer to the back brackets using two 1/4-20 x 2 carriage bolts and two 1/4-20 flange nuts on each side. Don't tighten the nuts until the front of the stabilizer frame is secure. Secure the front of the stabilizer frame to the rack rails using three 10-32 x 1/2 Phillips pan head screws with washers for each side. Then tighten the flange nuts on the carriage bolts.

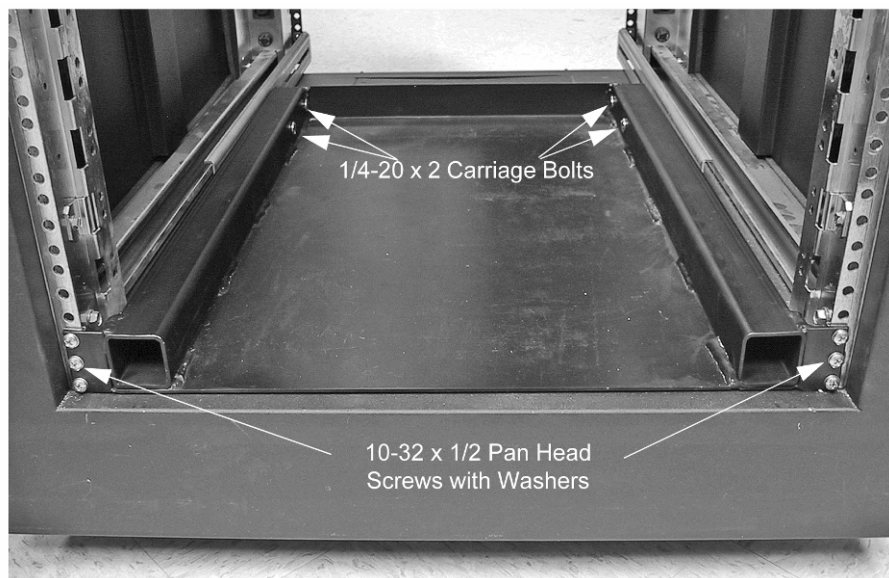

Front View

Shelf Installation

The library is mounted on a shelf with sliders, so it can be pulled out from the rack for servicing. The shelf requires 2U for installation. Alliance recommends mounting the shelf just above the stabilizer frame to keep the weight at the bottom of the rack. Do not mount the shelf more than 36" (91.4 cm) off the floor.

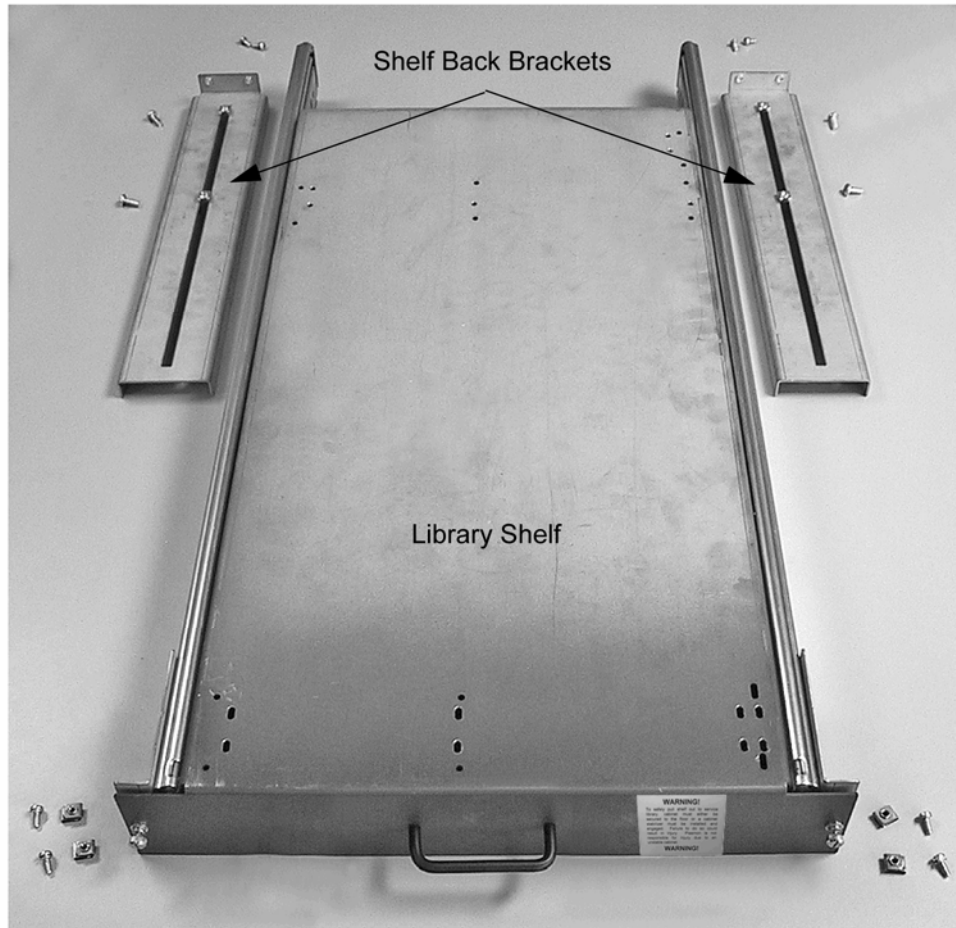

1. Install two 10-32 s-nuts on each of the front rack rails. Position the s-nuts on the center hole of each of the 2U spaces required for the shelf.

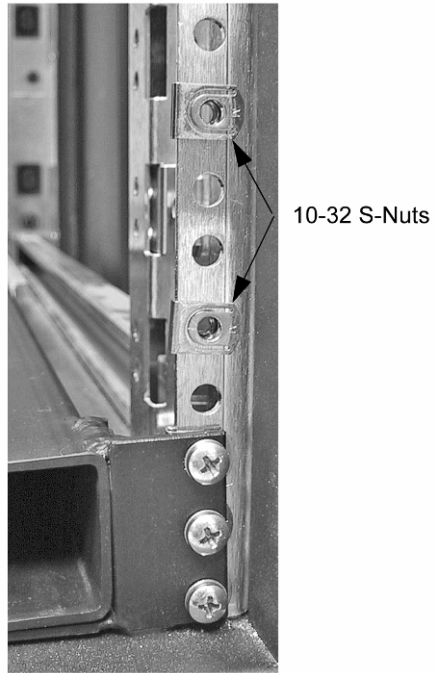

Front View

2. Install the back brackets (see read view picture below) using two 10-32 x ½ Phillips pan head screws with washers on each bracket.

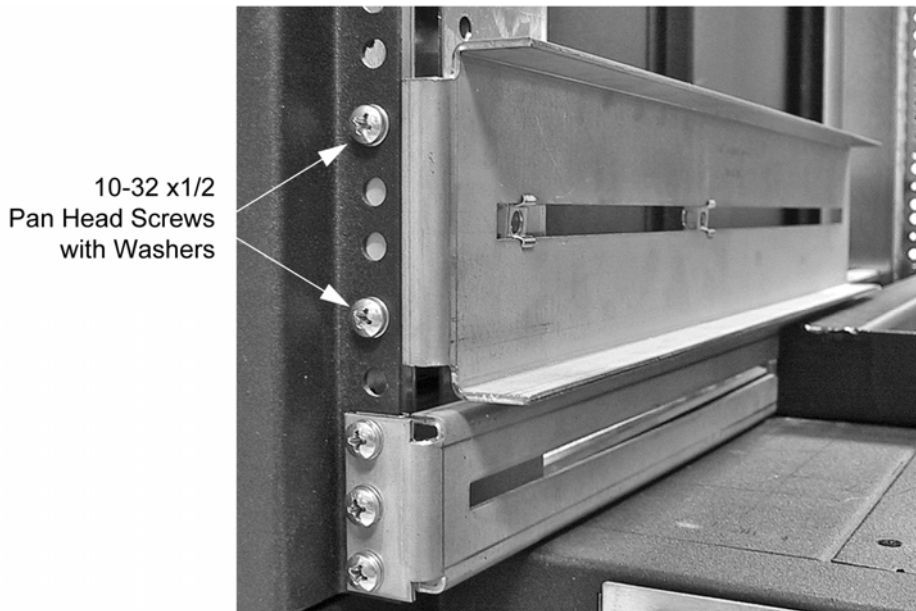

Rear View

3. Insert the stabilizer feet into the stabilizer frame and adjust the feet to rest firmly on the floor (unless the rack is self-stabilized). This helps support the shelf during installation.
4. Secure shelf to the front rack rails using two 10-32 x 1/2 Phillips pan head screws with washers on each side.

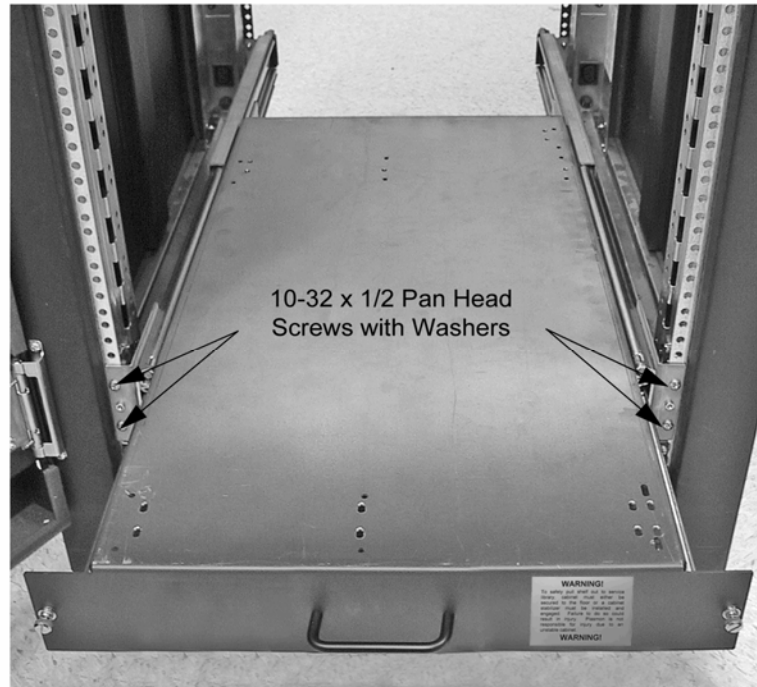

5. Screw the sliders to the back bracket using two 1/4-20 x 5/8 Phillips pan head screws for each side. These screws go into 1/4-20 cage nuts which slide in a groove on the back bracket to match up with the mounting holes in the slider.

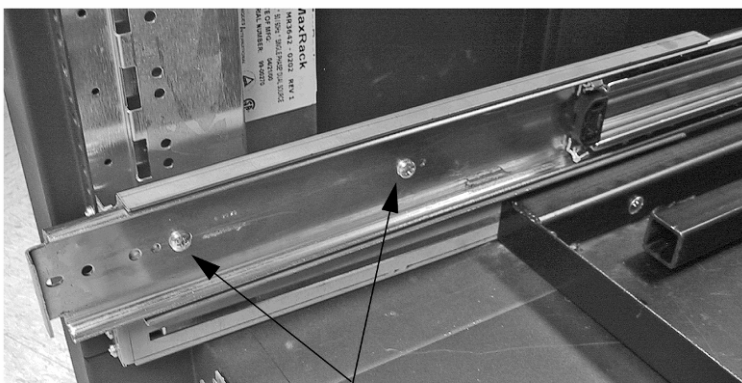

1/4-20 x 5/8 Pan Head Screws

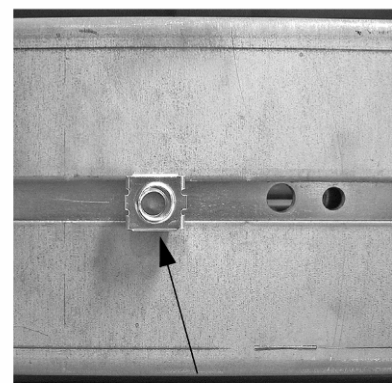

1/4-20 Cage Nut
Slides to align with hole.

If the front to back distance between mounting rails is less than 34" (86.4 cm), the mounting screw position falls behind the second section of the slider. A cut-out hole in the slider is provided for this. To access the cut-out hole, pull the shelf all the way out and pull back on the second slider section to line up the cut-out with the mounting hole in the back bracket.

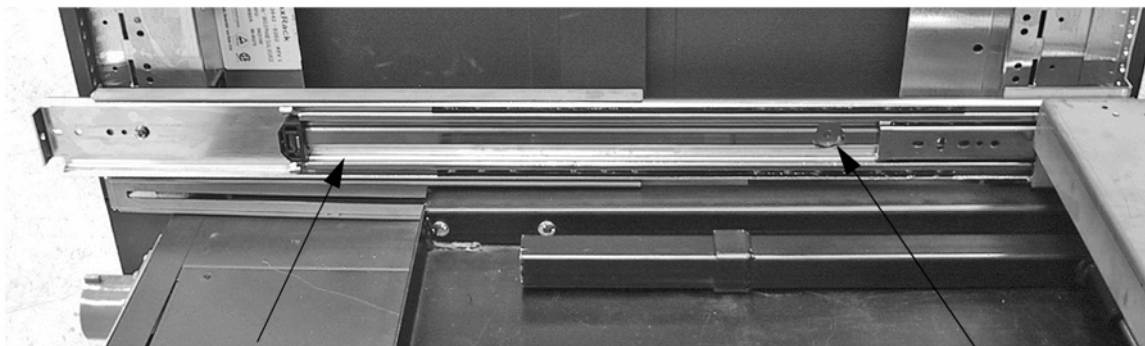

Second Slider Section

Cut-out Hole

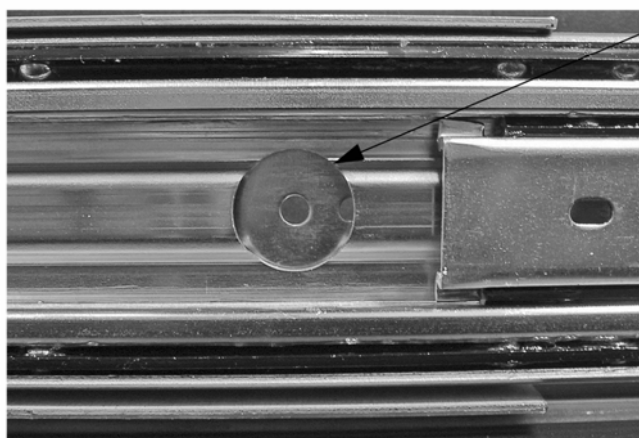

Library Installation

The library is mounted to the shelf. The casters, stabilizer channels, and any other hardware must be removed from the bottom of the library for rack mounting. The bottom of the library must be flat.

1. Ensure the Lift Lock Screw at the lower back of the library is engaged, and remove the front door, top skin, and both side skins from the library. Remove all media.
2. Place the heavy cardboard angle piece from the packaging on the floor as shown below to protect the back of the library. Lock the rear casters and carefully tilt the library onto its back to expose and completely remove the four casters, caster adapter plates if applicable, and the two frame channels.

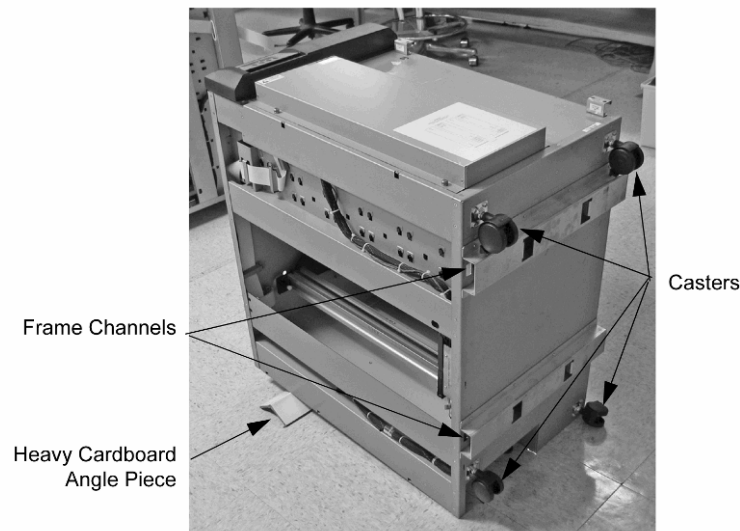

3. Carefully tilt the library back to the upright position.
4. Insert the stabilizer feet into the stabilizer frame and adjust the feet to rest firmly on the floor (unless the rack is self-stabilized).



5. Pull the shelf fully out and clamp the rails on both sides behind the shelf, as shown below, so it cannot slide.



6. Position the library about 16" (41 cm) in front of the shelf as shown in the picture below. The bottom of the library should face the shelf. Use the heavy cardboard packing piece to protect the back of the library.



7. Carefully tilt the library over so the bottom makes contact with the shelf.



8. Using proper lifting posture, slide the library onto the shelf.



9. Turn the library around so it faces out and place the library squarely on the shelf matching up the empty caster mounting holes with the holes in the shelf.

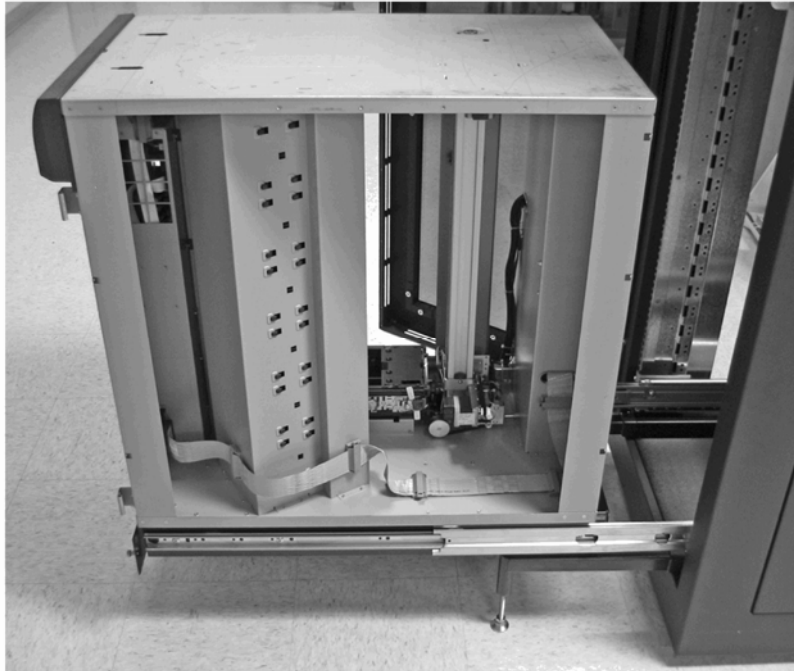

10. To make it easier to line up the mounting holes, look through the holes on the right side of the library from the top as shown below. Secure the library by placing 8-32 x 3/8 Phillips pan head screws through the shelf from the bottom into the two inside holes at all four corners.



11. Replace the top skin, both side skins, and the front door on the library.



12. Slide the library shelf back into the rack, and tighten the two locking thumb screws to keep it in place. Remove and store the stabilizer feet under the shelf for future use.

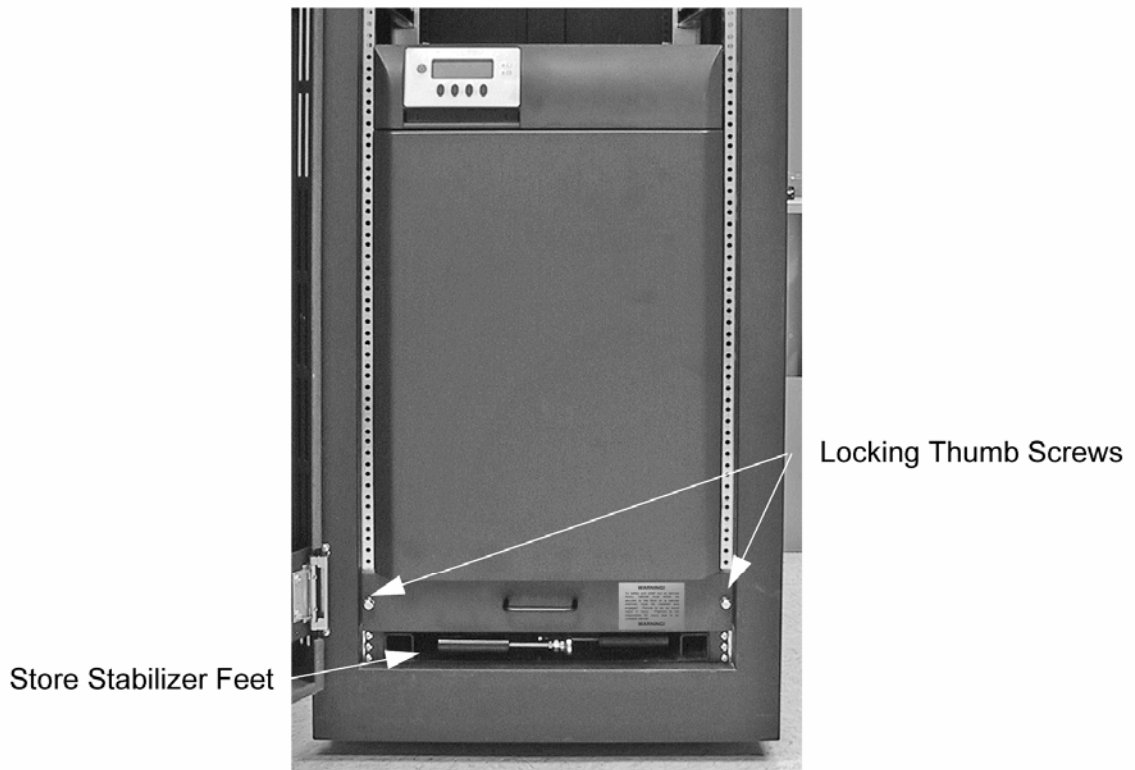

13. The narrower library chassis should sit to the right side of the shelf. An optional filler plate is available.



Packing Instructions

This section is provided in case it is necessary to ship the library back to Alliance. These procedures must be followed.

CAUTION



Plasmon Libraries must be shipped in the original packaging. Shipping a unit in anything other than the manufacturers packaging voids the warranty.

The library must be parked before packaging the system. Remove all media before shipping the library. Media can fall out of the storage elements during shipment.

The pictures in the following instructions show a Gx32, but all models pack the same.

Follow these steps to pack the library for shipping:

1. When the library is powered off, the media transport assembly moves to bottom of library. Remove the power cable from the library.
2. Turn the lift lock screw, located at the lower left in back of the library, all the way in using gentle pressure (do not force). This protects the MTA while moving the library.

CAUTION



The lift lock screw, shown below, must be turned clockwise all the way using gentle pressure (do not force) before moving the library. Failure to do so may seriously damage the library.

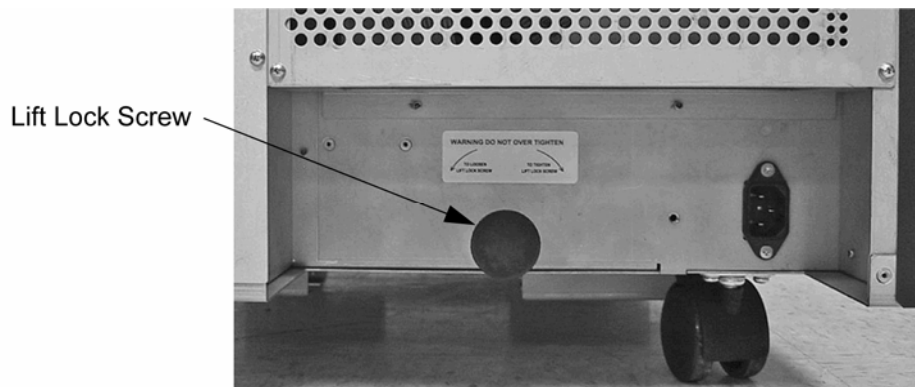

Figure 28. Packing the Gx Libraries

3. If library stabilizers are installed, remove them.
4. Place packaging skid with ramp on floor as shown below.



Figure 29. Packing the Gx Libraries

5. Using two people, roll library onto packaging skid. Back of library goes onto skid first.



Figure 30. Packing the Gx Libraries

6. Place bubble wrap to cover top and front of library.

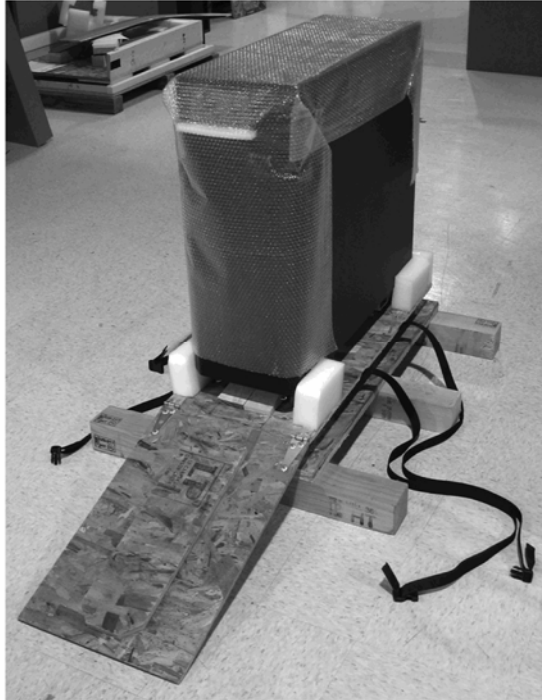

Figure 31. Packing the Gx Libraries

7. Cover the library with the anti-static bag.



Figure 32. Packing the Gx Libraries

8. Fit top foam pieces over library, and strap the library securely to the skid with the nylon strapping.

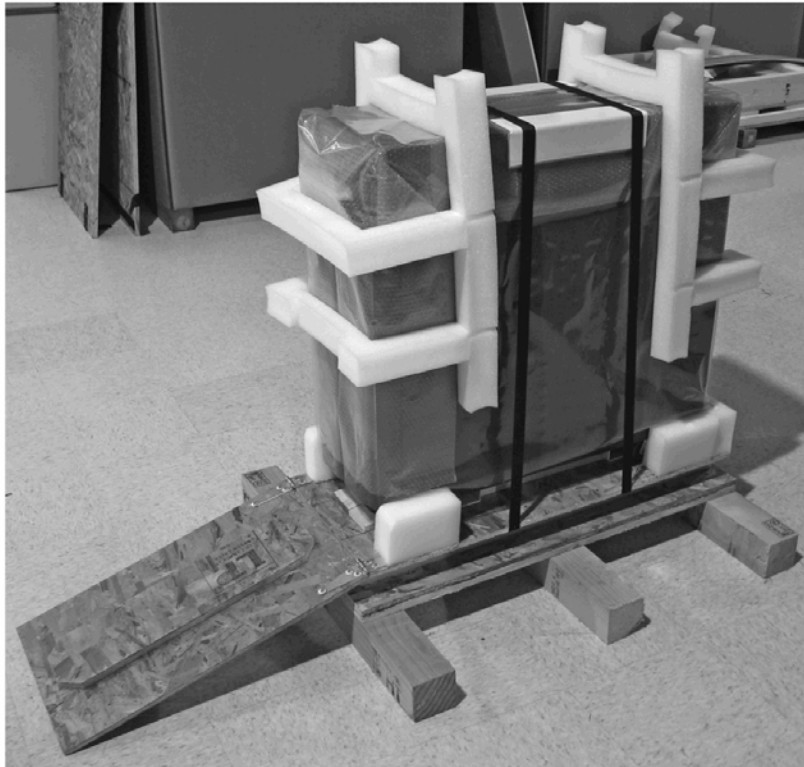

Figure 33. Packing the Gx Libraries

9. Raise the ramp to an upright position in front of library and tape it in place.

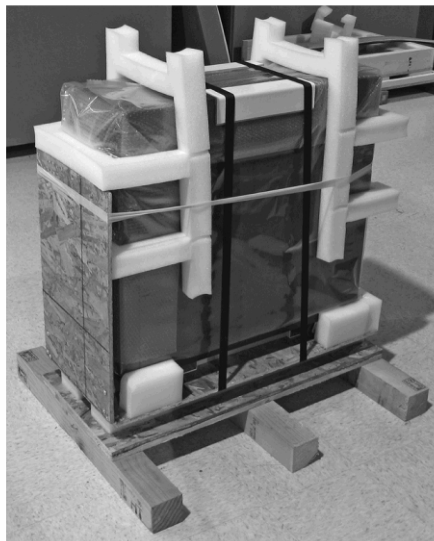

Figure 34. Packing the Gx Libraries

10. Place the cardboard sleeve over the library.

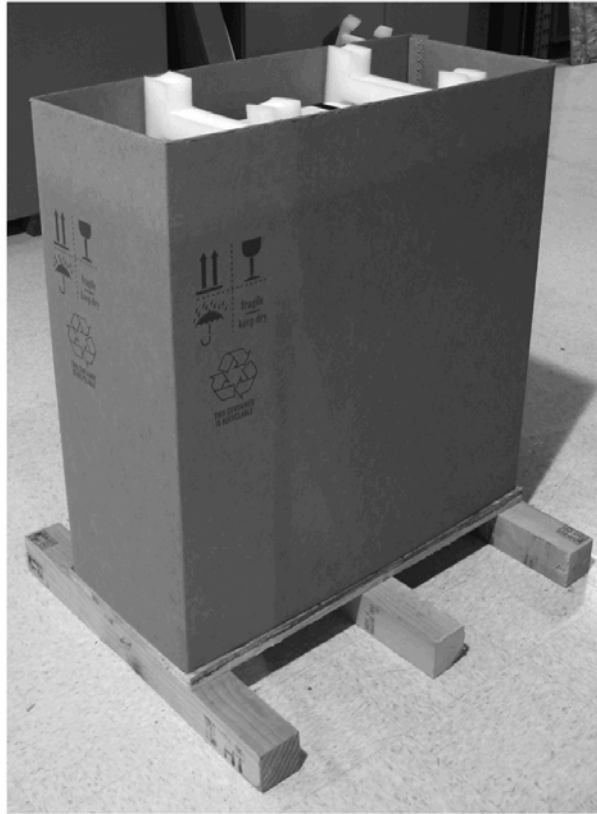

Figure 35. Packing the Gx Libraries

11. Place the accessory box, with any accessories, on the foam pieces on top of the library.



Figure 36. Packing the Gx Libraries

12. Place the lid in the box and finally, strap the box to the skid for shipping.



Figure 37. Packing the Gx Libraries

If the library is a Gx174, the four-way skid has holes for the side strapping to pass through. See picture below.

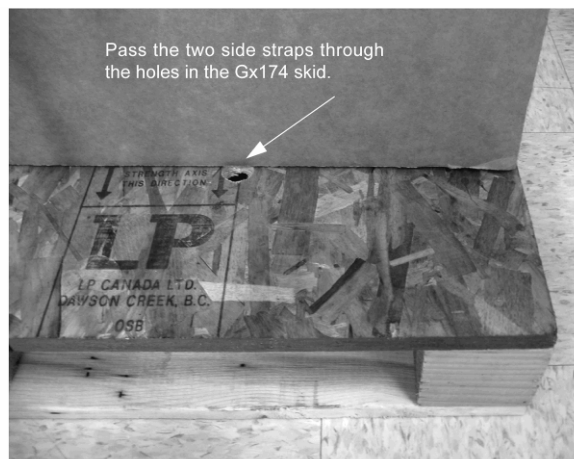

Figure 38. Gx174 Strapping Holes in Skid

CHAPTER 3

MENU SYSTEM (GX MODELS ONLY)

Navigating the Menu System

The Plasmon Gx library modes and functions are controlled using four selection buttons located on the front panel. A liquid crystal display (LCD), located directly above the buttons, provides system status and other important information.



Figure 39. LCD Display Format

The **Power On/Off Button** turns the library on, and when pushed twice, turns the library off.















The **Description Line** displays the number and name of the mode or test. An ellipsis (...) following a name indicates that the selection contains submenus.

The **Selection button Indicators** display the function of the four buttons located directly below the indicator. A dash above a button means that no function is associated with this key. The following LCD Symbols table provides an explanation of each symbol.

The **Activity LED** lights to indicate library activity.

The **On Line LED** lights to indicate library is on line and ready to receive SCSI commands.

Table 5. LCD Symbols

LCD Symbol	Meaning
	Enter a menu selection
	Exit a menu selection
	Change a mode selection
	Switch to display scroll mode
	Confirm a selection
	Decrement a numeric value or scroll display up
	Increment a numeric value or scroll display down
	Go to the previous menu item
	Go to the next menu item
	Display a list of menu items
	Indicates a drive is turned off or not present
	Indicates a media exists in an element
	Indicates the element is empty
	Indicates an error condition
	Clear counter

Power Up Menu Options

The following operations can be performed at the initial power up stage:

- Entering the library's main menu system
- Viewing error information

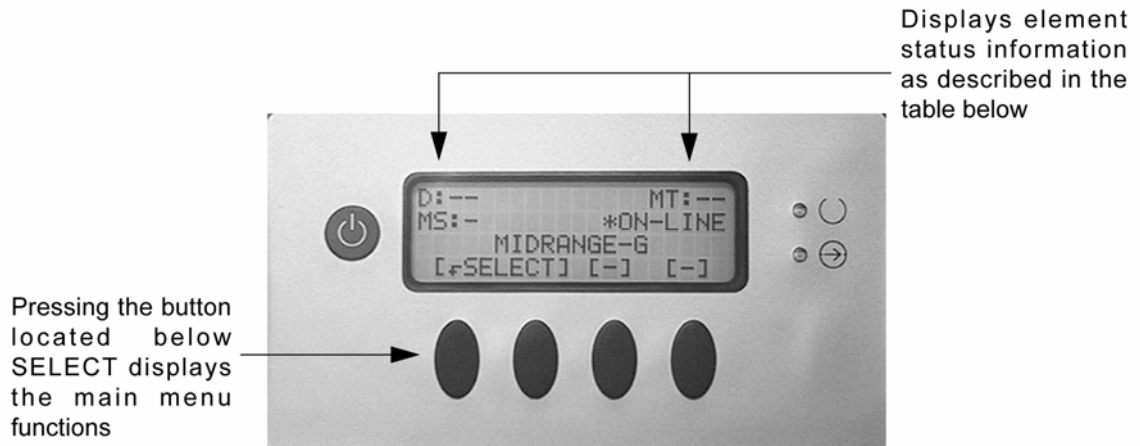

Figure 40. Power Up LCD Display

Table 6. Power Up LCD Symbols

Symbol	Meaning
D:	Drive status (drive present, media present)
MT:	Media transport assembly status (media present)
MS:	IO station status (media present)
—	Empty element or button not used
●	Media in element
•	Indicates drive is turned off or not present

Menu System Overview

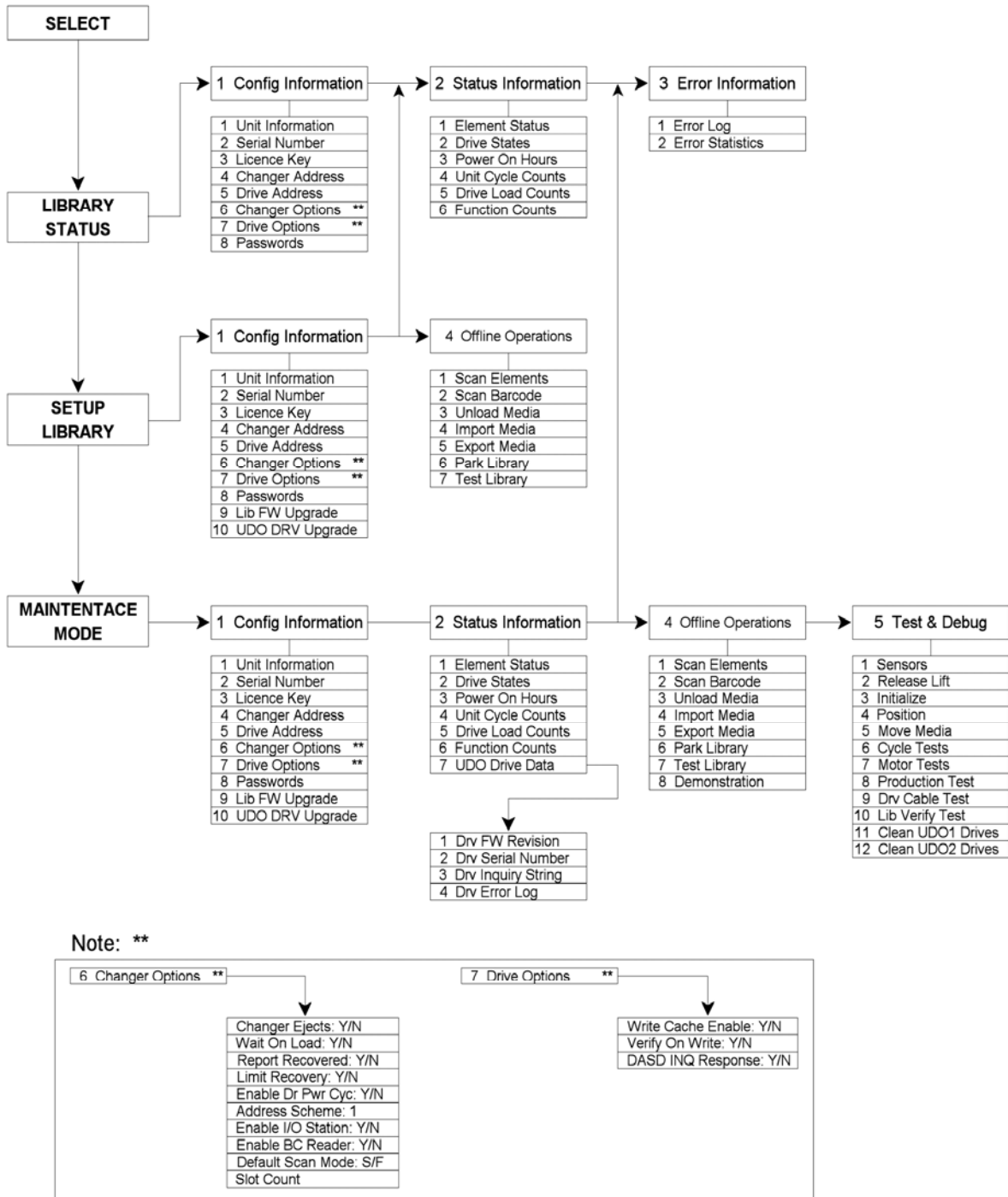

Figure 41. Menu System Overview

Main Menu Overview

The Library LCD menu system starts with three top-level options. To cycle through the options at any level press [**F** SELECT. To enter a selection press [**↵**].

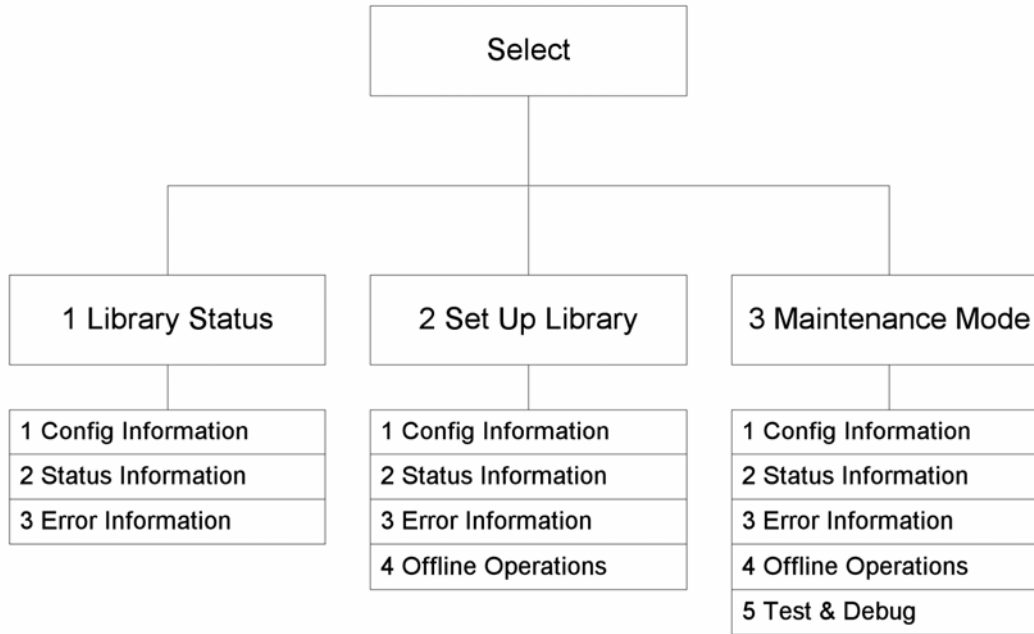

Figure 42. Main Menu Overview

Table 7. Main Menu Selections

Menu Selection	Description
1 Library Status	Allows viewing only of library settings. To make changes, use the Set Up menu.
2 Set Up Library	Allows viewing and changing of library settings. When performing operations from the Set Up menu, the library is taken off-line.
3 Maintenance Mode	Allows testing, setting up, or configuring the library. When performing operations from the Maintenance Mode menu, the library is taken off-line. These operations are reserved for Alliance authorized service personnel.

Library Status Menu Overview

Use the Library Status menu to view the library's status only. To make change to the library's status, use the Set Up Library menu.

The figure below shows the Library Status menu options.

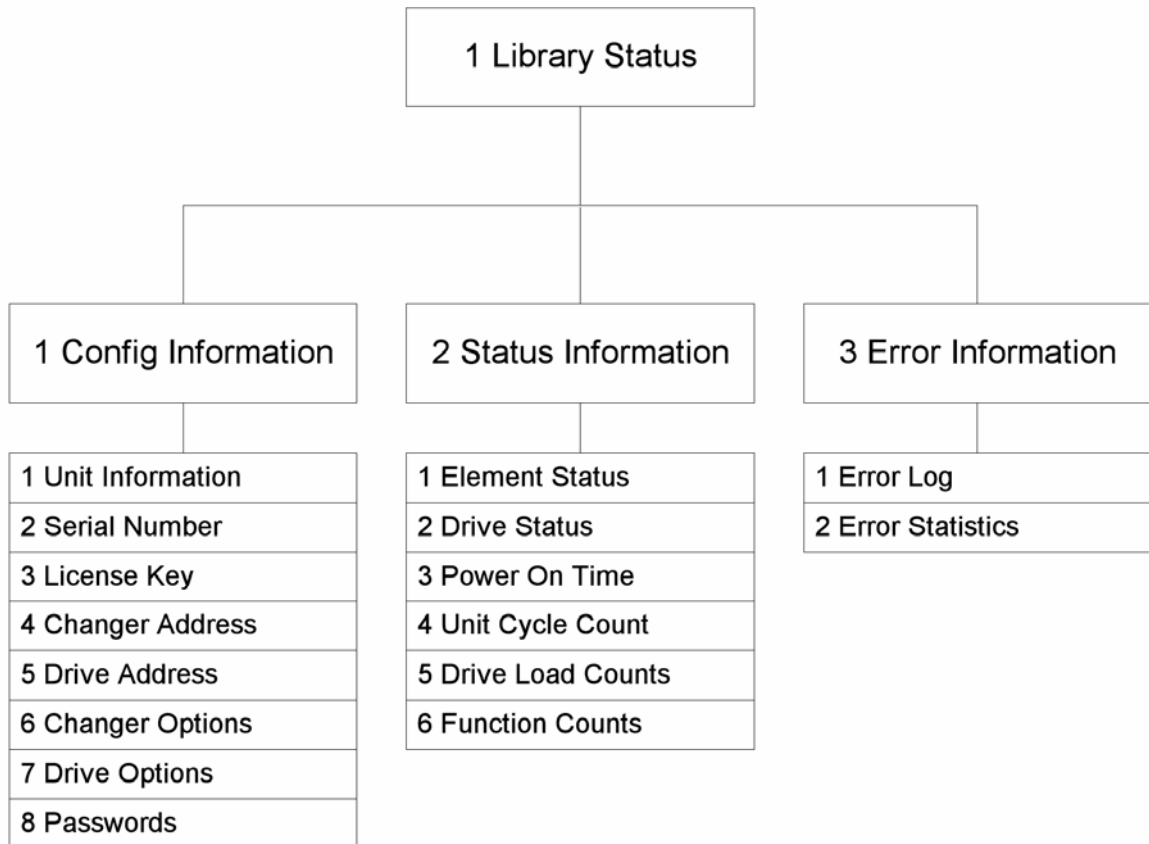

Figure 43. Library Status Menu Options

Table 8. Library Status Menu Selections

Menu Selection	Description	Factory Defaults
1 Config Information	Allows viewing only of library configuration settings.	--
1 Unit Information	To view the storage slot count, maximum drive count, and firmware revision.	--
2 Serial Number	To view the serial number assigned to the library.	--
3 License Key	To view the current slot license key assigned to the library.	--
4 Changer Address	To view the changer SCSI ID.	6
5 Drive Addresses	To view individual drive SCSI IDs.	0 - 5
6 Changer Options	To view changer options: Changer Ejects (Y/N) Wait on Load (Y/N) Report Recovered (Y/N) Limit Recovery (Y/N) Enable Drive Power Cycle (Y/N) Address Scheme (1/2) Enable IO Station (Y/N) Enable Barcode Reader (Y/N) Default Scan Mode (S/F) Slot Count (model dependent)	Y N N N N 1 N Y S --
7 Drive Options	To view drive options: Write cache enable (Y/N) Verify on write (Y/N) DASD inquiry response (Y/N)	N Y N
8 Passwords	Set passwords for: Library Status Set Up Library	--

Menu Selection	Description	Factory Defaults
2 Status Information	Allows viewing only of library status.	--
1 Element Status	To view which elements (picker, storage slot, IO station, or drive) are populated by media.	--
2 Drive States	To view the power on/off state of a drive.	--
3 Power-On Hours	To view total hours of power to library. Useful for preventive maintenance. Cannot be reset.	--
4 Unit Cycle Count	To view total cycle count since first startup. Cannot be reset.	--
5 Drive Load Counts	To view total selected drive loads since last reset of count.	--
6 Function Counts	To view total function counts since last reset of count. Lift Up/Down Count Picker1 In/Out Count Picker2 In/Out Count Change Picker Count Pivot L/R Col Count IO Station Open Count Cartridge Flip Count	--
3 Error Information	Allows viewing only of library error information.	--
1 Error Log	To view a chronological list of last ten errors since log was last cleared.	--
2 Error Statistics	To view a list of the ten most frequent errors since list was last cleared.	--

Set Up Library Menu Overview

Use the Set Up Library menu to change the library's status. When performing operations in the Set Up Library menu, the library is taken offline. Respond "yes" to the inquiry to take library off line. The factory default password for this function is "AAAA".

The figure below shows the Set Up Library menu options.

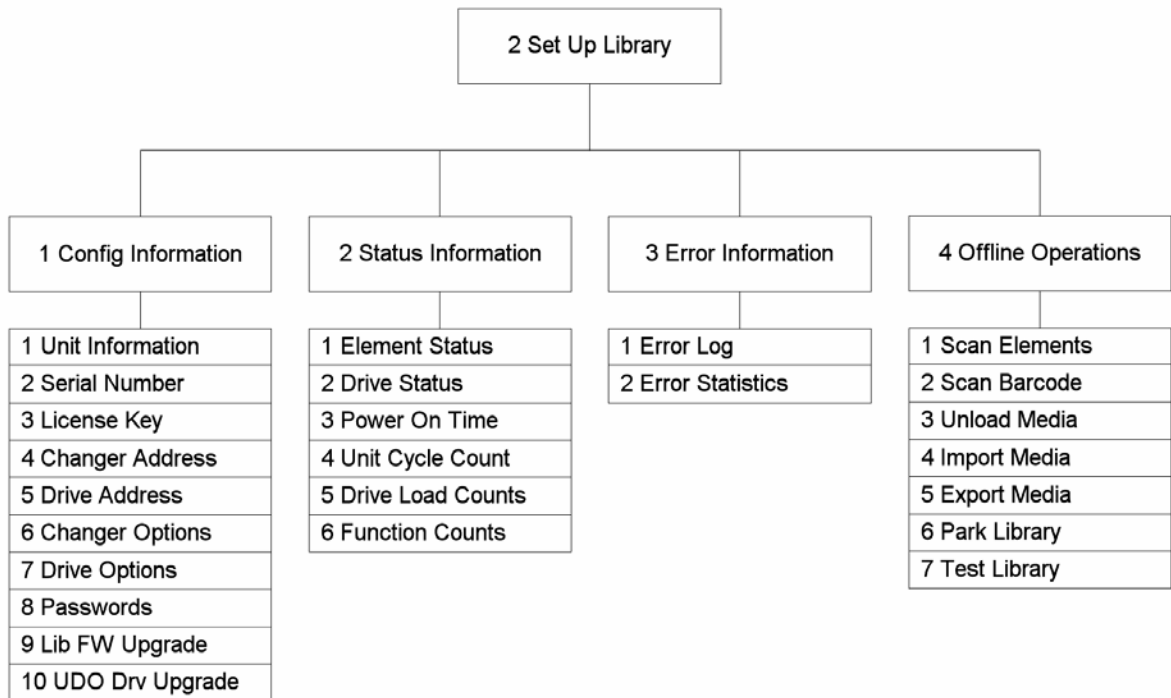

Figure 44. Set Up Library Menu Options

Table 9. Set Up Library Menu Selections

Menu Selection	Description	Factory Defaults
1 Config Information	Allows viewing and editing of library configuration settings.	--
1 Unit Information	To view the storage slot count, drive count, and firmware revision.	--
2 Serial Number	To view the serial number assigned to the library.	--
3 License Key	To view the current slot license key assigned to the library.	--
4 Changer Address	To view/set the changer SCSI ID. Set 0 - 15	6
5 Drive Addresses	To view/set individual drive SCSI IDs. Set 0 - 6 (default drive 1 = 0, drive 2 = 1, drive 3 = 2, drive 4 = 3)	0 - 5
6 Changer Options	To view/edit changer options: Changer Ejects (Y/N) Wait on Load (Y/N) Report Recovered (Y/N) Limit Recovery (Y/N) Enable Drive Power Cycle (Y/N) Address Scheme (1/2) Enable IO Station (Y/N) Enable BC Reader (Y/N) Default Scan Mode (S/F) Slot Count (model dependent) can only be changed in Maintenance Mode	Y N N N N 1 N Y S --
7 Drive Options	To view/edit drive options: Write cache enable (Y/N) Verify on write (Y/N) DASD inquiry response (Y/N)	N Y N
8 Passwords	Set passwords for: Library Status Set Up Library	--
9 Lib FW Upgrade	To upgrade library Firmware from an optical disk.	--
10 UDO Drv Upgrade	To upgrade drive FW from an optical disk.	--

Menu Selection	Description	Factory Defaults
2 Status Information	Allows viewing/editing of library status.	--
1 Element Status	To view/edit which elements (slots, drives, pick- ers, or I/O stations) are populated by media. Individual slot status can be set to full or empty.	--
2 Drive States	To view/edit a drive's on/off state.	--
3 Power-On Hours	To view total hours of power to library. Useful for preventive maintenance. Cannot be reset.	--
4 Unit Cycle Count	To view total cycle count since first startup. Cannot be reset.	--
5 Drive Load Counts	To view/reset total drive loads since last reset of count.	--
6 Function Counts	To view/reset total function counts since last reset of count. Lift Up/Down Count Picker1 In/Out Count Picker2 In/Out Count Change Picker Count Pivot L/R Col Count IO Station Open Count Cartridge Flip Count	--
3 Error Information	Allows viewing/clearing of library error information.	--
1 Error Log	To view/clear a chronological list of last ten errors since log was last cleared. The first on the list is the most recent.	--
2 Error Statistics	To view/clear a list of the ten most frequent errors since list was last cleared.	--
4 Offline Operations	Allows basic offline operations.	--
1 Scan Elements	To scan all elements.	--
2 Scan Barcode	To scan the barcode of a media.	--
3 Unload Media	To unload the drives.	--
4 Import Media	Moves media from IO station to storage slot.	--
5 Export Media	Moves media from storage slot to IO station.	--
6 Park Library	To park the picker before shipping or moving the library. Also, remove all media before mov- ing the library.	--
7 Test Library	To perform basic functionality tests. Moves a piece of media from a storage slot to every drive with a flip, then returns media to storage slot. This test is non-destructive.	--

Maintenance Mode Menu Overview

Use the Maintenance Mode menu to perform tests on, set up, or configure the library. When performing operations in the Maintenance Mode Library menu, the library is taken off-line. A password is required to enter this mode.

The following sequence of figures shows the Maintenance Mode menu options.

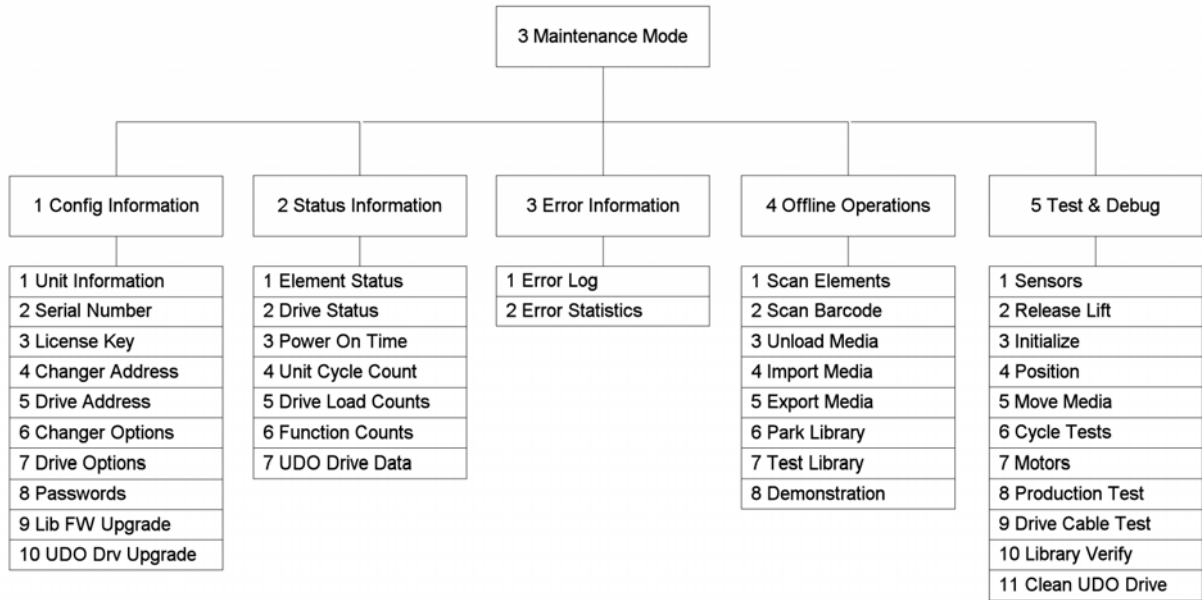

Figure 45. Maintenance Mode Menu Options

Table 10. Maintenance Mode Menu Selections

Menu Selection	Description	Factory Defaults
1 Config Information	Allows viewing and editing of library configuration settings.	--
1 Unit Information	To view the storage slot count, drive count, and firmware revision.	--
2 Serial Number	To view/change the serial number assigned to the library.	--
3 License Key	To view/change the current slot license key assigned to the library.	--
3 Changer Address	To view/set the changer SCSI ID.	6
4 Drive Addresses	To view/set individual drive SCSI IDs.	0 - 5
5 Changer Options	To view/edit changer options: Changer Ejects (Y/N) Wait on Load (Y/N) Report Recovered (Y/N) Limit Recovery (Y/N) Enable Drive Power Cycle (Y/N) Address Scheme (Y/N) Enable IO Station (Y/N) Enable BC Reader (Y/N) Default Scan Mode (S/F) Slot Count (model dependent) must recycle power after changing	Y N N N N 1 N Y S --
6 Drive Options	To view/edit drive options: Write cache enable ((Y/N) Verify on write (Y/N) DASD inquiry response (Y/N)	N Y N
7 Passwords	Set passwords for: Library Status Set Up Library	--
8 Library FW Upgrade	To upgrade library Firmware from an optical disk.	--
9 UDO Drive FW Upgrade	To upgrade drive FW from an optical disk.	--

Menu Selection	Description	Factory Defaults
2 Status Information	Allows viewing/editing of library status.	--
1 Element Status	To view/edit which elements (slots, drives, pickers, or I/O stations) are populated by media. Individual slot status can be set to full or empty.	--
2 Drive States	To view a drive's on/off state.	--
3 Power-On Hours	To view total hours of power to library. Useful for preventive maintenance. Cannot be reset.	--
4 Unit Cycle Count	To view total cycle count since first startup. Cannot be reset.	--
5 Drive Load Counts	To view/reset total drive loads since last reset of count.	--
6 Function Counts	To view/reset total function counts since last reset of count. Lift Up/Down Count Picker1 In/Out Count Picker2 In/Out Count Change Picker Count Pivot L/R Col Count IO Station Open Count Cartridge Flip Count	--
7 UDO Drive Data	To view UDO drive data. Drv FW Revision Drv Serial Number Drv Inquiry String Drv Error Log	--
3 Error Information	Allows viewing/clearing of library error information.	--
1 Error Log	To view/clear a chronological list of last ten errors since log was last cleared. The first on the list is the most recent.	--
2 Error Statistics	To view/clear a list of the ten most frequent errors since list was last cleared.	--

Menu Selection	Description	Factory Defaults
4 Offline Operations	Allows basic offline operations.	--
1 Scan Elements	To scan all elements.	--
2 Scan Barcode	To scan the barcode of a media.	--
3 Unload Drives	To unload the drives.	--
4 Import Media	Moves media from IO station to storage slot.	--
5 Export Media	Moves media from storage slot to IO station.	--
6 Park Library	To park the picker before shipping or moving the library. Also, remove all media before moving the library.	--
7 Test Library	To perform basic functionality tests. Moves a piece of media from a storage slot to every drive with a flip, then returns media to storage slot. This test is non-destructive.	--
8 Demonstration	To place library in demonstration mode.	--
5 Test & Debug		--
1 Sensors	Allows selection of individual sensors for manual testing. There is also an audible tone each time the sensor changes state.	--
Lift & Picker	To test/debug lift and picker components. Lift Pivot Home (0 = not blocked) Lift Auto Offset (1 = not blocked) Flip Home A (0 = not blocked) Flip Home B (0 = not blocked) Pick Home A (0 = not blocked) Pick Home B (0 = not blocked)	--
IO Station & Power	To test/debug IO Station and power components. IO Station Home (0 = not blocked) IO Station Door (1 = not blocked) IO Station Media (0 = not blocked) Front Fan A (1 = connected & running) Front Fan B (1 = connected & running) Rear Fan A (1 = connected & running) Rear Fan B (1 = connected & running) 24V Power (displays voltage) 12V Power (displays voltage) Temperature (displays temperature)	--

Menu Selection	Description	Factory Defaults
Drive 1 Drive 2 Drive 3 Drive 4	To test/debug drive components. Drive Sense (1 = connected) Drive Type (0 = MO, 1 = UDO) Drive Ready (1 = media spun up) Media Loaded (1 = media loaded) Media Present (1 = media present) LED 1 Pipe green (1 = On) LED 2 Pipe amber (1 = On) Drive Status (1 = drive error status available)	--
2 Release Lift	To remove the lift motor voltage so lift assembly drops	--
3 Initialize	To initialize the library. This option should be used before running any cycle tests.	--
4 Position	To move the MTA to a new site.	--
5 Move Media	To move media to a new location.	--
6 Cycle Tests	To perform cycle tests. Press the \leftarrow key to stop test.	--
Lift	To cycle lift. Moves lift up and down, and positions it at random locations. LCD displays locations and cycle count.	--
Pivot	To cycle the pivot mechanism.	--
Flip	To cycle flipper mechanism.	--
Storage Slot	To cycle media from a slot to the picker and back.	--
IO Station	To cycle media from the IO Station to the picker and back.	--
Drives	To cycle media from the picker to a drive and back.	--
7 Motors	Provides motion control of motors.	--
8 Production Test	Not applicable. For use on factory production floor only.	--
9 Drive Cable Test	To install media into a drive and confirm communication between drive and main controller.	--
10 Library Verify	Use the Basic Performance Test media only. Do not use customer media.	--
11 Clean UDO Drive	Use only the Plasmon UDO30GB Cleaning Cartridge in UDO30 drives. Use only the Plasmon UDO60GB Cleaning Cartridge in UDO60 drives. Follow the instructions on the cartridge case. There is also a demonstration presentation online at http://www.plasmontech.com/customer/player.html .	--

CHAPTER 4

AA PRODUCT INFORMATION

General Information

The Plasmon Archive Appliance™ is a Gx library with one of three optional network attached Storage Management Systems (SMS), the IAC A2, the A12 or the Elite E12. All Gx models may be selected for an A2 SMS. The A12 SMS or Elite E12 SMS apply to all Gx models except Gx24 and Gx32.

A12

The Plasmon AA20-80 A12 Series and AA100-174 A12 Series SMS unit includes a RAID resident cache that assembles data for migration to optical media. This function shares the RAID capacity and performance with user data file operations. A12 RAID uses from two to twelve 1TB SATA HDDs.

E12 Elite

The Elite SMS on Plasmon Elite AA20-80 E12 Series and Elite AA100-174 E12 Series includes a high speed SSD (solid state drive) cache for data migration that operates independently of the RAID. The RAID uses a hardware controller card and two to twelve 2TB SAS HDDs. In addition, the hardware includes a battery-backed cache for RAID data transfers, a quad Zeon MPU, and high speed motherboard.

IAC A2

The A2 SMS is an internally mounted dual drive assembly with integral controller PCA and external power supply.



Figure 46. . Elite SMS Unit on 174 Library

Archive Appliance Configurations

The dual column AA20-80 Series models may be configured with A2, A12 or E12 Elite SMS.

The dual column dual height AA100-174 Series models may be configured with A2, A12 or E12 Elite SMS.

The single column AA16-32 Series may be configured with A2 SMS.

Table 11. . Archive Appliance Configurations

Model	Maximum Number Licensed Media Slots	Max Number UDO Drives	HDD Drives Available for RAID
AAxxx-A12	xxx = 80, 174	2	2,4,8 or 12 Sata
AAxxx-A12	xxx = 20, 40, 60, 72, 134, 166	4	2,4,8 or 12 Sata
AAxxx-A12	xxx = 100, 120, 140, 158	6	2,4,8 or 12 Sata
AAxxx-A2	xxx = 16, 32, 80, 174	2	2
AAxxx-A2	xxx = 20, 40, 60, 72, 134, 166	4	2
AAxxx-A2	xxx = 100, 120, 140, 158	6	2
Elite AAxx-E12	xxx = 80, 174	2	2,4,8 or 12 SAS
Elite AAxxx-E12	xxx = 20, 40, 60, 72, 134, 166	4	2,4,8 or 12 SAS
Elite AAxxx-E12	xxx = 100, 120, 140, 158	6	2,4,8 or 12 SAS

Major Hardware Components

The following figures show the locations of major library hardware components. In these figures the protective panels and outer skin of the library are removed.

A brief description of these components appears at the end of this section. For details regarding the SMS and complete archive configuration information, please refer to the Plasmon Archive Appliance SMS Administration Guide.

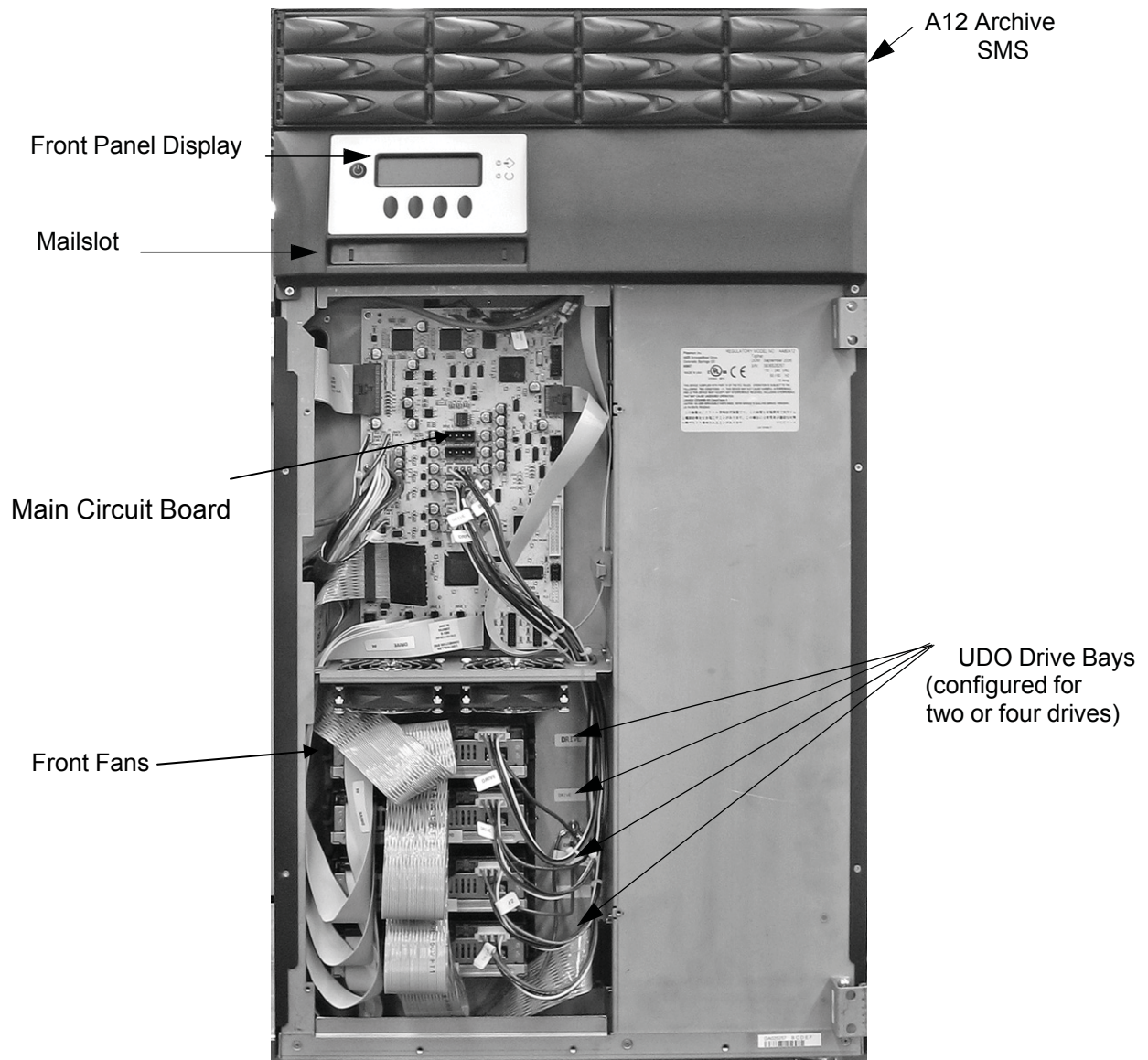

Figure 47. AA80A12, Front View

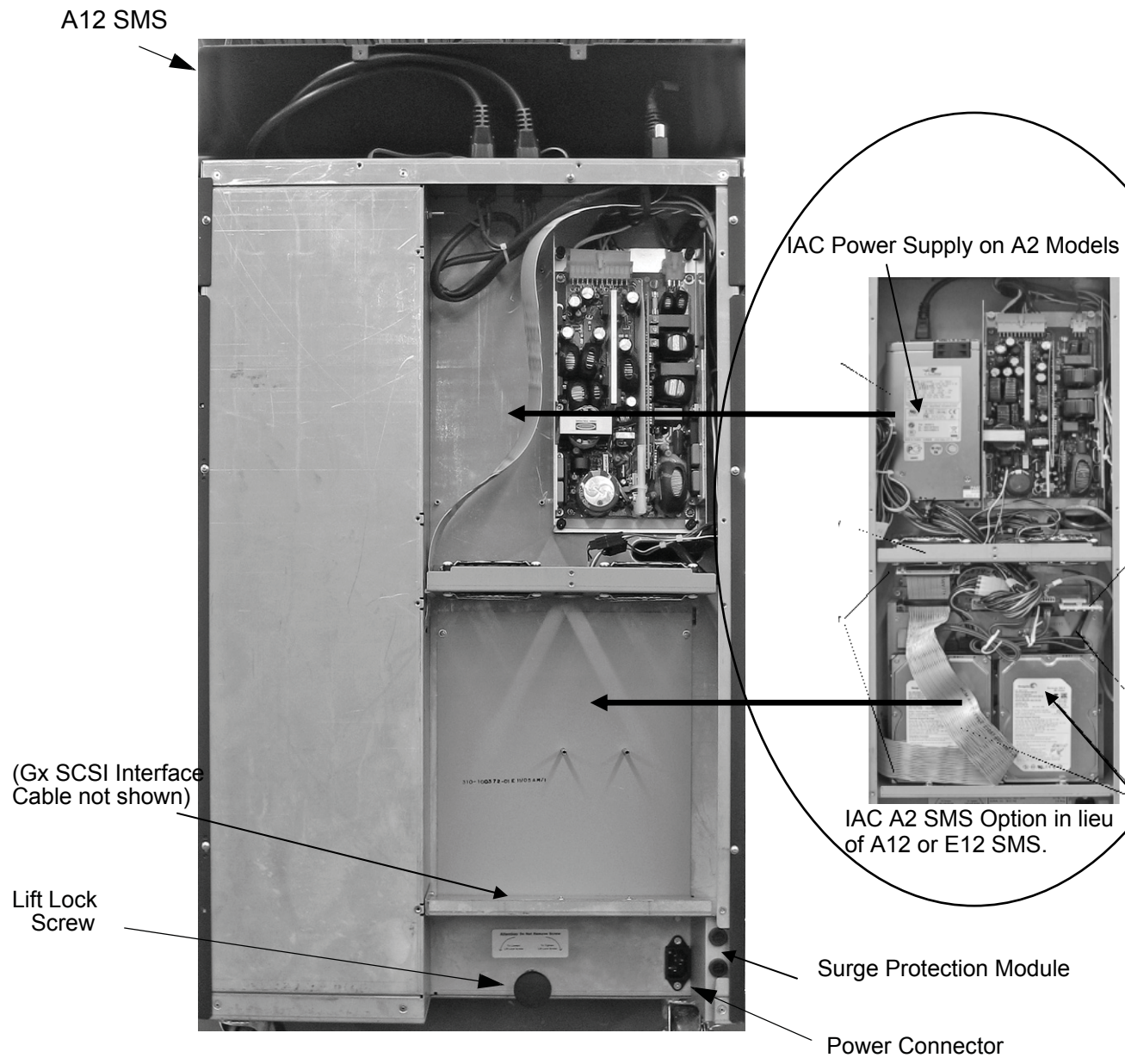

Figure 48. AA80A12, Rear View

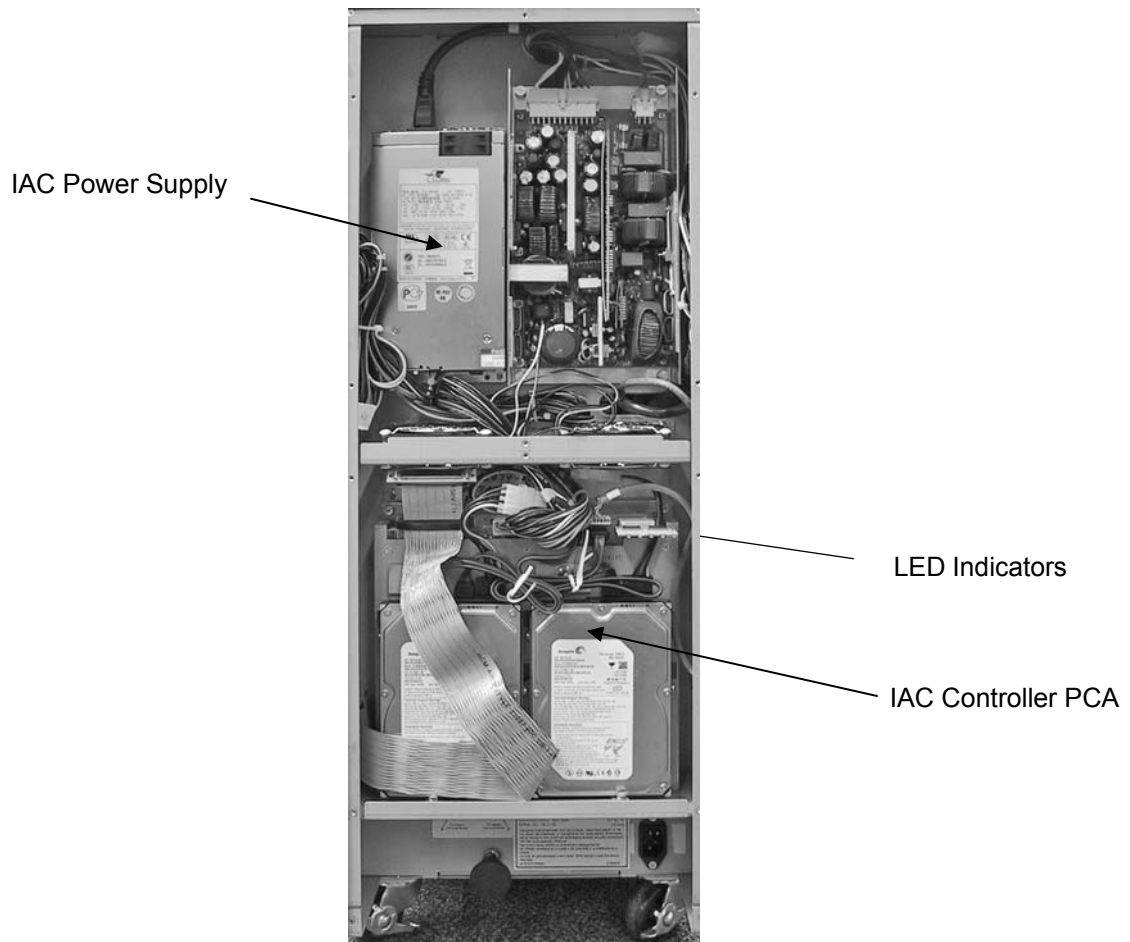

Figure 49. AA16 & AA32 with IAC A2 Archive Controller

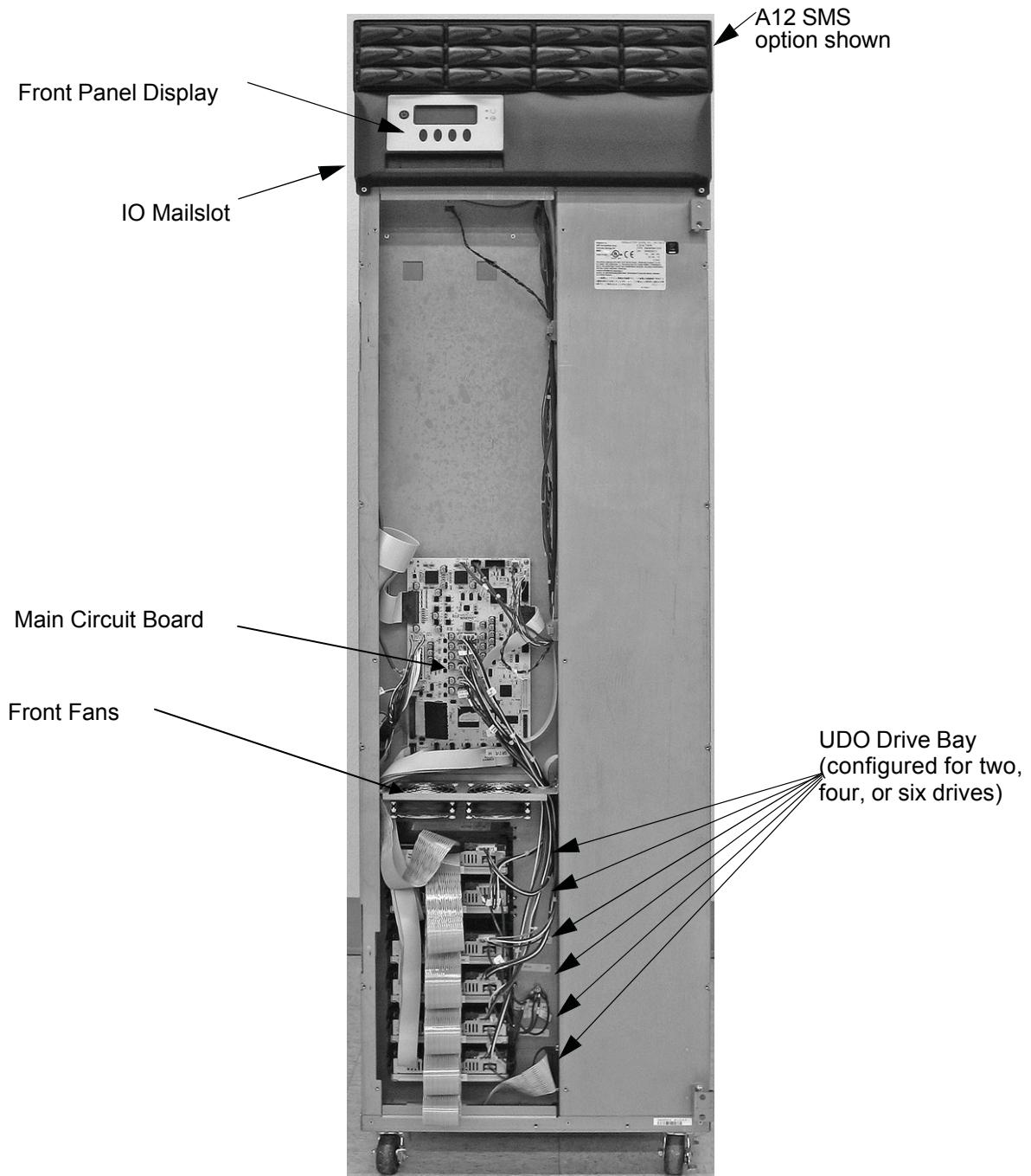

Figure 50. AA174A12, Front View

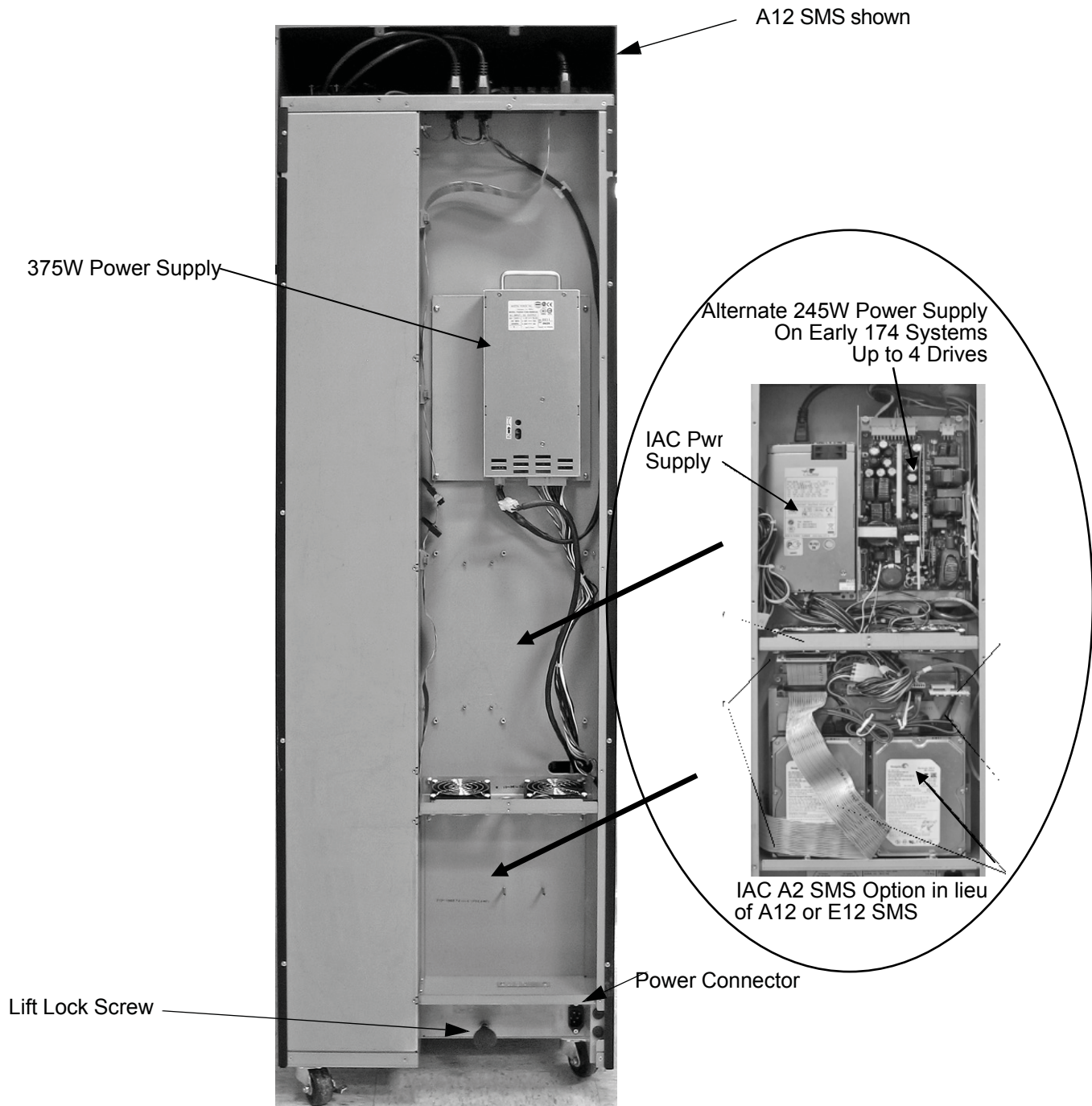

Figure 51. AA174A12, Rear View

IAC SMS & IAC Power Supply Option

AAxx models include the IAC (A2) SMS mounted below the rear library power supply and a 250W ATX type power supply. Also, a 245W library power supply is used on early Gx174 limited to 4 drives. All Elite models use the 375W library power supply.

Front Panel Display

The front panel display consists of the keypad and display window, which provide the operator interface to the system. It is used to display user related status.

Mailslot

The automated mailslot is capable of importing and exporting single media while the library is on-line.

UDO Drives

The drives used in the library component allow reading and writing of data. They are fully tested to work with the library. This library uses UDO drives only.

SMS

The Storage Management System is the network attached hardware with the RAID cache and the installed Plasmon Archive Appliance Software. Models are A2 IAC, A12, and E12.

SATA Drives

The SATA (Serial ATA) drives in the A12 SMS provide the A12 software RAID cache data storage.

SAS Drives

The SAS (Serial Attached SCSI) drives in the E12 SMS provide the data storage for battery-backed hardware RAID card.

Lift Lock Screw

The lift lock screw secures the MTA during shipment or whenever moving the library.

Power Connector

The power connector is used to supply power to the system.

Media Store

The media store holds each media in place. It consists of vertically arranged plates with plastic grooved guide panels that hold each media.

Media Transport Assembly (MTA)

The media transport assembly moves media between storage locations and the drives or the mailslot, and consists of the dual picker and flip assembly.

Installing the RAID Hard Disk Drives

The drives which provide the RAID cache are packaged separately in the shipping container. To install them in the SMS, follow the steps below.

1. Remove the drives from their packaging.
2. Each drive is shipped in a drive shuttle. Disengage the release lever lock on the shuttle by pushing it to the right. Then pull the release lever all the way out.



Figure 52. Drive Release Lever and Lock (SATA HDDs Shown)

3. If the setup is for two SATA Drives, mount them in the left most positions of the top row of the A12. If the setup is for eight or more SATA / SAS drives, mount them in the bottom two rows of the AA. Mount blanks in the rest of slots. Carefully insert the shuttle into the drive location in the AA unit. Push the shuttle all the way into the slot, completing the insertion by closing the release lever.

SMS Cable Connections

Power, SCSI, Ethernet, and UPS cables connect to the back of the A12 unit as shown below.

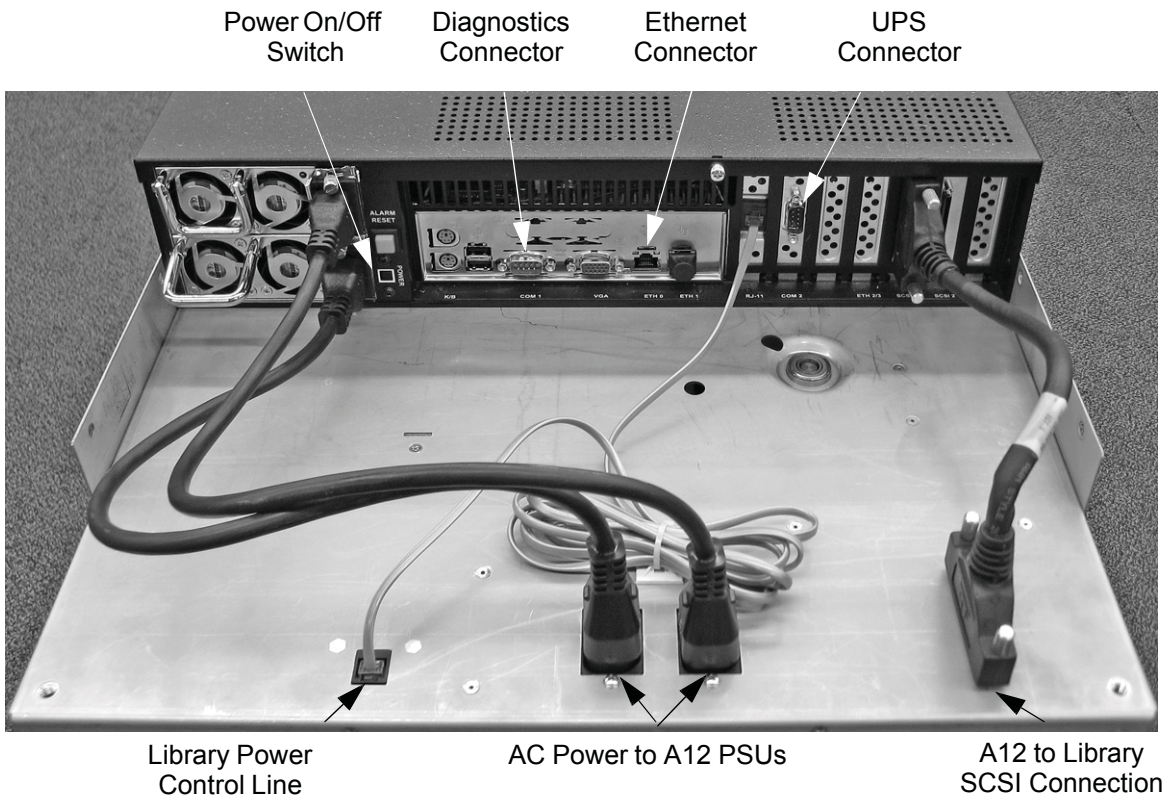

Figure 53. A12 SMS Unit Back Panel

Dual Power Inlets Diagnostic Connectors Dual 1Gb Ethernet Library Power Control Line UPS Connector SCSI to Library

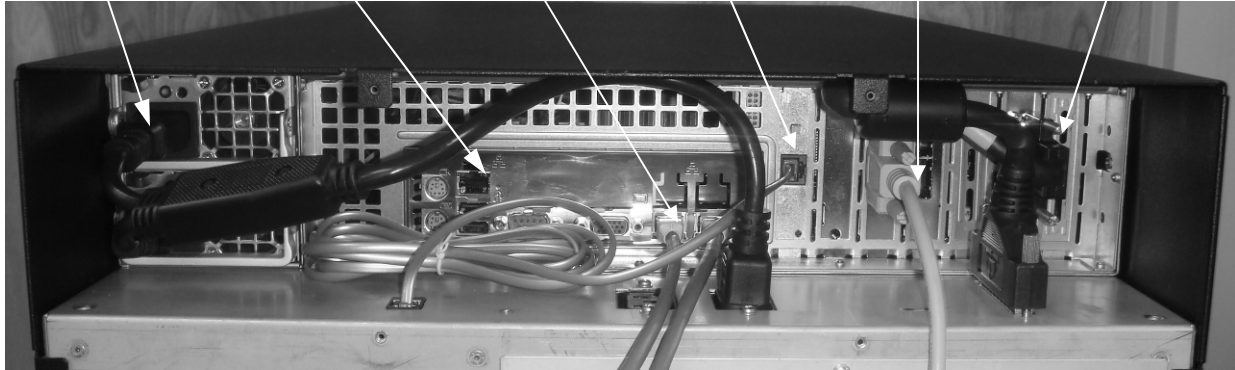

Figure 54. E12 Elite SMS Unit Back Panel

The SMS unit communicates with the library through the SCSI connection.

The entire Archive Appliance communicates with a network through one or two ethernet connectors. CAT6 shielded cabling is required for full bandwidth Gigabit networks.

For network setup, please refer to the *Archive Appliance Quick Start Guide*. The Diagnostics connector is provided for Alliance Storage Technologies, Inc. trained service personnel.



CAUTION: EXTRA RJ45 CONNECTOR

A third RJ45 connector shown above with the E12 SMS diagnostic connector group is not an active Ethernet port for archive communications. *Do not use the third Ethernet connector, as it is not supported.*

AA SYSTEM Initial Power On

Alliance Storage Technologies, Inc. recommends the following initial start up procedure:

1. Bulk load media into the library before powering on the system.
2. Connect the recommended UPS.
3. Power on the system by pressing the power button on the library front panel display.

CAUTION



To shut down the archive appliance always use the network GUI interface to initiate orderly shut down of the RAID system. Never hold the SMS unit rear power switch or front panel power switch.

4. After initial power on, the Archive Appliance software must be configured. Please refer to the software *Quick Start Guide*.

AA SYSTEM Power-Down

Use the following procedure to prevent SMS system data loss during power turn-off.

CAUTION



To shut down the archive appliance always use the network GUI interface to initiate orderly shut down of the RAID system. Never hold the SMS unit rear power switch or front panel power switch.

From the GUI Select **Shutdown > Shutdown** to power off the Appliance.
Do not attempt to abort the initialization of an AA system before the GUI is ready.

Or from the CLI Run: `/etc/init.d/smb stop`
`/etc/init.d/nfs stop`
`ssm stop`
`poweroff`

SMS LED Indicators

The A12 SMS has a row of three LED indicators on the front left corner of the A12 SMS unit. Labels on the side of the unit identify these indicators. A blue light indicates proper conditions, red indicates a fault.



Figure 55. A12 SMS LED Indicators

The E12 Elite SMS units do not have side mounted Unit LED Indicators. The status is reported through the front panel display of the library. An audible alarm sounds when a fault occurs.

Both A12 and E12 units also report alarm status through the network GUI and SMTP messages.

The A12 SATA drives have two LED indicators at the right front corner of each drive shuttle. The top LED lights blue to indicate a drive is powered on. The bottom LED lights blue to indicate drive activity, or red to indicate a drive fault. The E12 SAS drives have an upper Blue LED that turns on with power and flashes with activity. The lower SAS LED is steady Red for failure condition and flashes for Hot Spare indication.



Figure 56. A12 SATA HDD LED Indicators



Figure 57. E12 SAS HDD LED Indicators

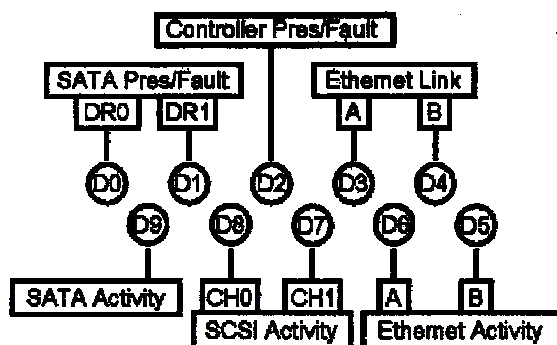

Figure 58. A2 SMS LED Legend Label

Table 12. Archive Controller LED Signals

LED	State	Indication
D0. SATA DR0 Pres/Fault	Red	Fault or missing
	Green	Present
D1. SATA DR1 Pres/Fault	Red	Fault or missing
	Green	Present
D2. Controller Pres/Fault	Red	Fault
	Green	Present
D3. Eth0 Link	Green	Ethernet connection
	Off	No Ethernet connection
D4. Eth1 Link	Green	Ethernet connection
	Off	No Ethernet connection
D5. Eth0 Activity	Flashing Yellow	Activity
	Off	No Activity
D6. Eth1 Activity	Flashing Yellow	Activity
	Off	No Activity
D7. SCSI Activity CH0	Flashing Yellow	No activity
	Off	Activity
D8. SCSI Activity CH0	Flashing Yellow	No activity
	Off	Activity
D9. SATA Activity	Flashing Yellow	Activity
	Off	No activity

APPENDIX A

GX SERIES SPECIFICATIONS

Gx Series Libraries

Specifications are subject to change without notice.

Table 13. Gx24 – 32 and Gx20 - 80 Series Library Specifications

Specification	Gx24	Gx32	Gx72	Gx80
Library Capacity (UDO60)	1.44TB	1.92TB	4.32TB	4.8TB
Library Capacity (UDO30)	720GB	960GB	2.16TB	2.4TB
Library Capacity (MO)	218GB	291GB	655GB	728GB
Max Number of Storage Slots	24	32	72	80
Number of Drives	Up to 2	Up to 2	Up to 4	Up to 2
Drive Types Supported	UDO / MO	UDO / MO	UDO / MO	UDO / MO
Library Reliability (MSBF) 1 swap = 1 SCSI exchange	>2,000,000	>2,000,000	>2,000,000	>2,000,000
Robotics Avg. Access Time	<6.1 sec.	<6.1 sec.	<6.1 sec.	<6.1 sec.
Picker Type	Dual	Dual	Dual	Dual
Automated IO Station	single	single	single	single
Max Power Dissipation	161 W 423 BTU/hr.	161 W 423 BTU/hr.	219 W 520 BTU/hr.	166 W 440 BTU/hr.
Library Interface/Connector	Wide Ultra 2 LVD (auto-sensing), SCSI-2 / HD68 FE connector			
Options To purchase these options or other upgrades, contact a Alliance Sales office or local distributor.	Barcode Scanner 19" Rack Mount SCSI Redrive (LVD) Lights & Windowed Side Panel			
Power Requirements Voltage/Current Frequency Operating Current	100 to 240 VAC (universal) / 3.5A 50/60 Hz 1.3 Arms @ 120V, G72			

Specification	Gx24	Gx32	Gx72	Gx80
Environmental Operating Temperature Operating Humidity Non-Operating Temperature	+10 to +32°C (+50 to +90°F) 10 to 90% RH non-condensing -30 to +60°C (-22 to +140°F)			
Space Requirements Width (in/cm) Height (in/cm) Depth (in/cm) <i>Minimum airflow: 3" behind unit and 2" on both sides</i>	29.1 / 73.9 30.5 / 77.5 34.2 / 86.9		35.5 / 90.2 30.5 / 77.5 34.2 / 86.9	
Dimensions-Stand Alone Width with Stabilizers (in/cm) Height (in/cm) Depth (in/cm) Weight (lbs/kg)	29.1 / 73.9 30.5 / 77.5 31.2 / 79.2 120 / 54		35.5 / 90.2 30.5 / 77.5 31.2 / 79.2 153 / 70	
Dimensions-Rack Mount Width (in/cm) Height (in/cm) Rackmount Units Mounting Hardware Rack Units Depth (in/cm) Weight (lbs/kg)	11.1 / 28.8 27.8 / 70.6 16U 3U 31.2 / 79.2 120 / 54		17.5 / 44.5 27.8 / 70.6 16U 3U 31.2 / 79.2 153 / 70	
Dimensions-Shipping Width (in/cm) Height (in/cm) Depth (in/cm) Weight (lbs/kg)	24 / 61 42 / 104 37 / 94 178 / 81		32 / 81 42 / 107 37 / 94 223 / 102	

Table 14. Gx174 Series Library Specifications

Specification	Gx174	Gx166	Gx158
Library Capacity (UDO60)	10.44TB	9.96TB	9.48TB
Library Capacity (UDO30)	5.22TB	4.98TB	4.74TB
Library Capacity (MO)	1.58TB	1.51TB	1.44TB
Max Number of Storage Slots	174	166	158
Number of Drives	Up to 2	Up to 4	Up to 6
Drive Types Supported	UDO/MO	UDO/MO	UDO/MO
Library Reliability (MSBF) 1 swap = 1 SCSI exchange	>2,000,000	>2,000,000	>2,000,000
Robotics Avg. Access Time	<8.2 sec.	<8.2 sec.	<8.2 sec.
Picker Type	Dual	Dual	Dual
Automated IO Station	Single	Single	Single
Max Power Dissipation	170 W 454 BTU/hr.	223 W 534 BTU/hr.	275 W 614 BTU/hr.
Library Interface / Connector	Wide Ultra 2 LVD (auto-sensing), SCSI-2 / HD68-pin high density female connector		
Options To purchase these options or other upgrades, contact a Alliance Sales office or local distributor.	Bar Code Reader SCSI Redrive (LVD) 19" Rack Mount Lights & Windowed Side Panel		
Power Requirements Voltage/Current Frequency	100 to 240 VAC (universal) / 3.5A 50/60 Hz		

Specification	Gx174	Gx166	Gx158
Environmental Operating Temperature Operating Humidity Non-Operating Temperature	+10 to +32°C (+50 to +90°F) 10 to 90% RH non-condensing -30 to +60°C (-22 to +140°F)		
Space Requirements Width with Stabilizers (in/cm) Height (in/cm) Depth (in/cm) <i>Minimum airflow: 3" behind unit and 2" on both sides</i>	35.5/90.2 54.6 / 138.8 33.8 / 85.9		
Dimensions-Stand Alone Width (in/cm) Width with Stabilizers (in/cm) Height (in/cm) Depth (in/cm) *Weight (lbs/kg)	17.5 / 44.5 35.5 / 90.2 54.6 / 138.8 30.8 / 78.2 240 / 110		
Dimensions-Rack Mount Width (in/cm) Height (in/cm) Rackmount Units Mounting Hardware Rack Units Depth (in/cm) Weight (lbs/kg)	17.5 / 44.5 52.0 / 132 30U 3U 31.2 / 79.2 153 / 70		
Dimensions-Shipping Width (in/cm) Height (in/cm) Depth (in/cm) *Weight (lbs/kg)	36 / 92 66 / 168 37 / 94 338 / 155		

*Each UDO/MO media cartridge installed adds 6 oz. to the overall weight of the system.

AA-A2-IAC Series Libraries

Specifications are subject to change without notice.

Table 15. AA32 A2 & AA80 A2 Series Specifications

Specification	AA16A2	AA32A2	AA72A2	AA80A2
Library Capacity (UDO60)	960GB	1.92TB	4.32TB	4.8TB
Number of Media Storage Slots	16	32	72	80
Number of Drives	Up to 2	Up to 2	Up to 4	Up to 2
Drive Type Supported	UDO60 OR UDO30			
Library Reliability (MSBF)	>2,000,000			
Robotics Avg. Access Time	<7 sec.		<7.3 sec.	
Picker Type	Dual		Dual	
Automated Mailslot	Single		Single	
Library Interface (Dual)	10/100/Gigabit Ethernet (copper)			
Options	Windowed Side Panel; Lights; 19" Rack Mount; Extension Library			
Max Power Dissipation	251 Watts 730 BTU/hr	251 Watts 730 BTU/hr	309 Watts 827 BTU/hr	256 Watts 747 BTU/hr
Power Requirements Voltage/Current Frequency Operating Current	100 to 240 VAC (universal) / 3.5A 50/60 Hz 1.8 Arms @ 120V, AA32A2			
Environmental Operating Temperature Operating Humidity Non-Operating Temperature	+10 to +32°C (+50 to +90°F) 10 to 90% RH non-condensing -30 to +60°C (-22 to +140°F)			
Space Requirements Width w/Stabilizers (in/cm) Height (in/cm) Depth (in/cm) <i>Includes minimum airflow of 3" behind unit and 2" on both sides</i>	29.1 / 73.9 30.5 / 77.5 34.2 / 86.9		35.5 / 90.2 34 / 86.4 34.2 / 86.9	
Dimensions-Stand Alone Width w/Stabilizers (in/cm) Width (in/cm) Height (in/cm) Rackmount Units Mounting Hardware Rack Units Depth (in/cm) Weight (lbs/kg)	29.1 / 73.9 11.1 / 28.8 30.5 / 77.5 16U 3U 31.2 / 79.2 130 / 59		35.5 / 90.2 17.5 / 44.5 30.5 / 77.5 18U 3U 31.2 / 79.2 163 / 74	
Dimensions-Shipping Width (in/cm) Height (in/cm) Depth (in/cm) Weight (lbs/kg)	24 / 61 42 / 104 37 / 94 188 / 85		32 / 81 42 / 107 37 / 94 233 / 106	

Table 16. AA174 A2 Series Specifications

Specification	AA158A2	AA166A2	AA174A2
Library Capacity (UDO60)	9.48TB	9.96TB	10.44TB
Number of Media Storage Slots	158	166	174
Number of Drives	Up to 6	Up to 4	Up to 2
Drive Types Supported	UDO60 OR UDO30		
Library Reliability (MSBF)	2,000,000		
Robotics Avg. Access Time	<8.3 sec.		
Picker Type	Dual		
Automated Mailslot	Single		
Max Power Dissipation	361 Watts 908 BTU/hr	309 Watts 827 BTU/hr	256 Watts 747 BTU/hr
Library Interface (Dual)	10/100/Gigabit Ethernet (copper)		
Options	Windowed Side Panel; Lights; 19" Rack Mount; Extension Library		
Power Requirements Voltage/Current Frequency Operating Current	100 to 240 VAC (universal) / 4A 50/60 Hz 1.8 Arms @ 120V, AA174A2		
Environmental Operating Temperature Operating Humidity Non-Operating Temperature	+10 to +32°C (+50 to +90°F) 10 to 90% RH non-condensing -30 to +60°C (-22 to +140°F)		
Space Requirements Width w/stabilizers (in/cm) Height (in/cm) Depth w/stabilizer (in/cm) <i>Includes minimum airflow of 3" behind unit and 2" on both sides</i>	35.5 / 90.2 58.1 / 147.6 41.8 / 106.2		
Dimensions-Stand Alone Width w/stabilizers (in/cm) Width (in/cm) Height (in/cm) Rackmount Units Mounting Hardware Rack Units Depth (in/cm) Depth w/stabilizer (in/cm) Weight (lbs/kg)	35.5 / 90.2 17.5 / 44.5 58.1 / 147.6 30U 3U 30.8 / 78.2 38.8 / 98.6 305 / 139		
Dimensions-Shipping Width (in/cm) Height (in/cm) Depth (in/cm) Weight (lbs/kg)	36 / 92 76 / 193 37 / 94 405 / 184		

AA-A12 Series Libraries

Specifications are subject to change without notice.

Table 17. AA80 A12 Series Specifications

Specification	AA72A12	AA80A12
Library Capacity (UDO60)	4.32TB	4.8TB
Library Capacity (UDO30)	2.16TB	2.4TB
Number of Media Storage Slots	72	80
Number of Drives	Up to 4	Up to 2
Drive Type Supported	UDO30 or UDO60	
Library Reliability (MSBF)	>2,000,000	
Robotics Avg. Access Time	<6.1 sec.	
Picker Type	Dual	
Automated Mailslot	Single	
Library Interface (Dual)	10/100/Gigabit Ethernet (copper)	
Options	Windowed Side Panel 19" Rack Mount; Extension Library	
Max Power (8 HDD) Dissipation	513 Watts 1525 BTU/hr	482 Watts 1419 BTU/hr
Power Requirements Voltage/Current Frequency Operating Current	100 to 240 VAC (universal) / 10A 50/60 Hz 3.7 Arms @ 120V, AA72A12 8Hdd	
Environmental Operating Temperature Operating Humidity Non-Operating Temperature	+10 to +32°C (+50 to +90°F) 10 to 90% RH non-condensing -30 to +60°C (-22 to +140°F)	
Space Requirements Width w/Stabilizers (in/cm) Height (in/cm) Depth (in/cm) <i>Includes minimum airflow: 3" behind unit and 2" on both sides</i>	35.5 / 90.2 34.0 / 86.4 34.2 / 86.9	
Dimensions-Stand Alone Width (in/cm) Width w/Stabilizers (in/cm) Height (in/cm) Rackmount Units Mounting Hardware Rack Units Depth (in/cm) Weight (lbs/kg)	17.5 / 44.5 35.5 / 90.2 34.0 / 86.4 18U 3U 31.2 / 79.2 209 / 95	
Dimensions-Shipping Width (in/cm) Height (in/cm) Depth (in/cm) Weight (lbs/kg)	32 / 82 51 / 130 37 / 94 281 / 128	

Table 18. AA174 A12 Series Specifications

Specification	AA158A12	AA166A12	AA174A12
Library Capacity (UDO60)	9.48TB	9.96TB	10.44TB
Library Capacity (UDO30)	4.74 TB	4.98TB	5.22TB
Number of Media Storage Slots	158	166	174
Number of Drives	Up to 6	Up to 4	Up to 2
Drive Types Supported	UDO30, or UDO60		
Library Reliability (MSBF)	>2,000,000		
Robotics Avg. Access Time	<8.2 sec.		
Picker Type	Dual		
Automated Mailslot	Single		
Max Power (8 HDD) Dissipation	544 Watts 1617 BTU/hr	513 Watts 1512 BTU/hr	482 Watts 1406 BTU/hr
Library Interface (Dual)	10/100/Gigabit Ethernet (copper)		
Options	Windowed Side Panel; Extension Library; 19" Rack Mount		
Power Requirements Voltage/Current Frequency Operating Current	100 to 240 VAC (universal) / 10A 50/60 Hz 4.0 Arms @120V, AA158A12 (8 HDD)		
Environmental Operating Temperature Operating Humidity Non-Operating Temperature	+10 to +32°C (+50 to +90°F) 10 to 90% RH non-condensing -30 to +60°C (-22 to +140°F)		
Space Requirements Width w/stabilizers (in/cm) Height (in/cm) Depth w/stabilizer (in/cm) <i>Includes minimum airflow of 3" behind unit and 2" on both sides</i>	35.5 / 90.2 58.1 / 147.6 37.4 / 95.0		
Dimensions-Stand Alone Width (in/cm) Width w/stabilizers (in/cm) Height (in/cm) Rackmount Units Mounting Hardware Rack Units Depth w/stabilizer (in/cm) Weight (lbs/kg)	17.5 / 44.5 35.5 / 90.2 58.1 / 147.6 32U 3U 34.4 / 87.4 301 / 137		
Dimensions-Shipping Width (in/cm) Height (in/cm) Depth (in/cm) Weight (lbs/kg)	36 / 92 76 / 193 37 / 94 401 / 183		

AA-E12 Series Libraries

Specifications are subject to change without notice.

Table 19. AA80 Elite Series Specifications

Specification	AA72E12	AA80E12
Library Capacity (UDO60)	4.32TB	4.8TB
Number of Media Storage Slots	72	80
Number of Drives	Up to 4	Up to 2
Drive Type Supported	UDO60	
Library Reliability (MSBF)	>2,000,000	
Robotics Avg. Access Time	<6.1 sec.	
Picker Type	Dual	
Automated Mailslot	Single	
Library Interface (Dual)	10/100/Gigabit Ethernet (copper)	
Options	Windowed Side Panel; Lights; 19" Rack Mount; Extension Library	
Max Power (12 HDD) Dissipation	495 Watts 1576 BTU/hr	460 Watts 1471 BTU/hr
Power Requirements Voltage/Current Frequency Operating Current	100 to 240 VAC (universal) / 6A 50/60 Hz 3.9 Arms @ 120V, AA72E12	
Environmental Operating Temperature Operating Humidity Non-Operating Temperature	+10 to +32°C (+50 to +90°F) 10 to 90% RH non-condensing -30 to +60°C (-22 to +140°F)	
Space Requirements Width w/Stabilizers (in/cm) Height (in/cm) Depth (in/cm) <i>Includes minimum airflow of 3" behind unit and 2" on both sides</i>	35.5 / 90.2 34 / 86.4 34.2 / 86.9	
Dimensions-Stand Alone Width (in/cm) Width w/Stabilizers (in/cm) Height (in/cm) Rackmount Units Mounting Hardware Rack Units Depth (in/cm) Weight (lbs/kg)	17.5 / 44.5 35.5 / 90.2 34.0 / 86.4 18U 3U 31.2 / 79.2 213 / 97	
Dimensions-Shipping Width (in/cm) Height (in/cm) Depth (in/cm) Weight (lbs/kg)	32 / 82 51 / 130 37 / 94 281 / 128	

Table 20. AA174 Elite Series Specifications

Specification	AA158E12	AA166E12	AA174E12
Library Capacity (UDO60)	9.48TB	9.96TB	10.44TB
Number of Media Storage Slots	158	166	174
Number of Drives	Up to 6	Up to 4	Up to 2
Drive Types Supported	UDO60		
Library Reliability (MSBF)	2,000,000		
Robotics Avg. Access Time	<8.2 sec.		
Picker Type	Dual		
Automated Mailslot	Single		
Max Power Dissipation	530 Watts 1682 BTU/hr	495 Watts 1576 BTU/hr	460 Watts 1471 BTU/hr
Library Interface (Dual)	10/100/Gigabit Ethernet (copper)		
Options	Windowed Side Panel; Lights; Extension Library; 19" Rack Mount		
Power Requirements	Voltage/Current 100 to 240 VAC (universal) / 6A Frequency 50/60 Hz Operating Current 4.1 Arms @ 120V, AA158E12		
Environmental	Operating Temperature +10 to +32°C (+50 to +90°F) Operating Humidity 10 to 90% RH non-condensing Non-Operating Temperature -30 to +60°C (-22 to +140°F)		
Space Requirements	Width w/stabilizers (in/cm) 35.5 / 90.2 Height (in/cm) 58.1 / 147.6 Depth w/stabilizer (in/cm) 41.8 / 106.2 <i>Includes minimum airflow of 3" behind unit and 2" on both sides</i>		
Dimensions-Stand Alone	Width w/stabilizers (in/cm) 35.5 / 90.2 Width (in/cm) 17.5 / 44.5 Height (in/cm) 58.1 / 147.6 Rackmount Units 32U Mounting Hardware Rack Units 3U Depth (in/cm) 30.8 / 78.2 Depth w/stabilizer (in/cm) 38.8 / 98.6 Weight (lbs/kg) 305 / 139		
Dimensions-Shipping	Width (in/cm) 36 / 92 Height (in/cm) 76 / 193 Depth (in/cm) 37 / 94 Weight (lbs/kg) 405 / 184		

APPENDIX B

SCSI BUS INFORMATION

SCSI Bus Configuration

The following section shows the SCSI bus configurations for the Plasmon Gx libraries.

Please refer to the SCSI Connection section of Chapter 2 Library Installation in this manual for information on appropriate SCSI cables, connectors, and termination.

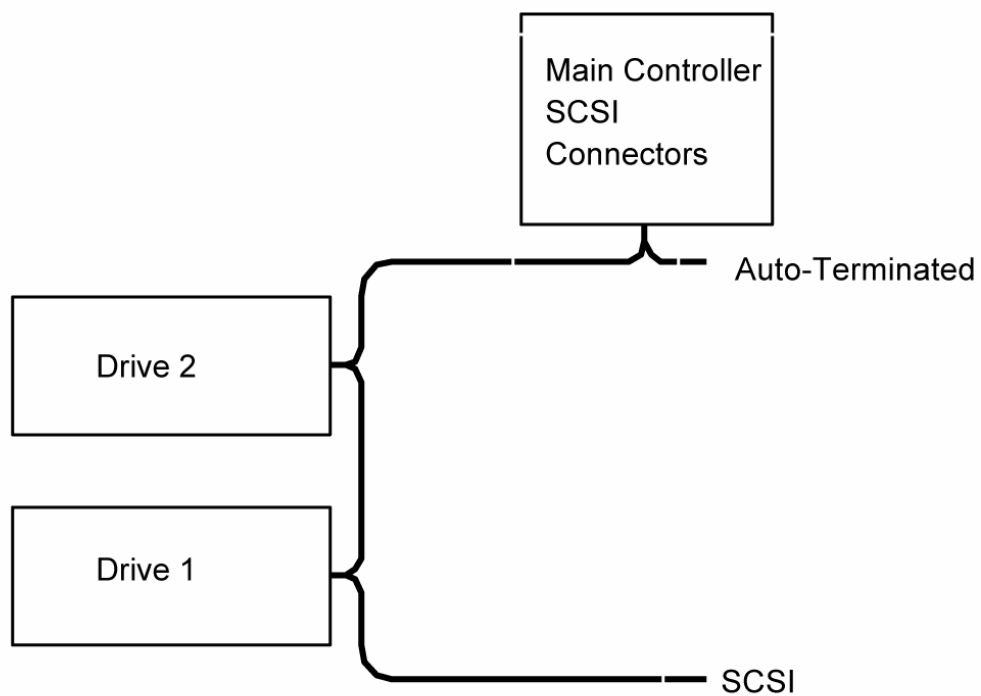

Figure 59. SCSI Bus Configuration for the Gx (2 drives)

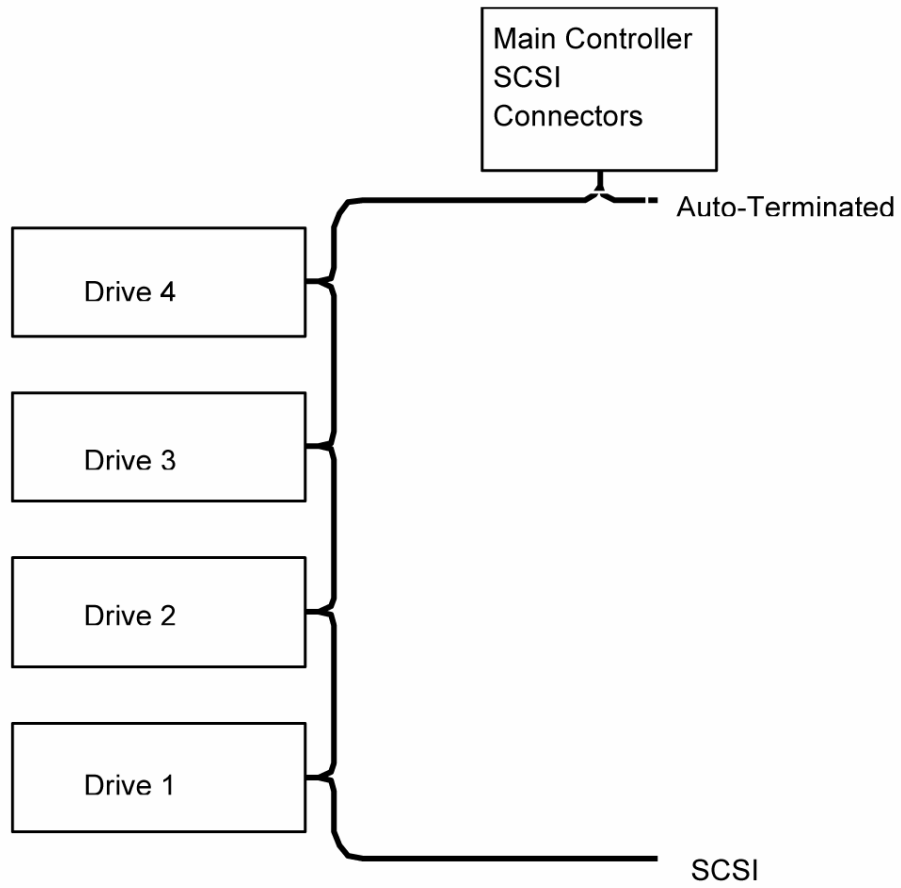

Figure 60. SCSI Bus Configuration for the Gx (4 drives)

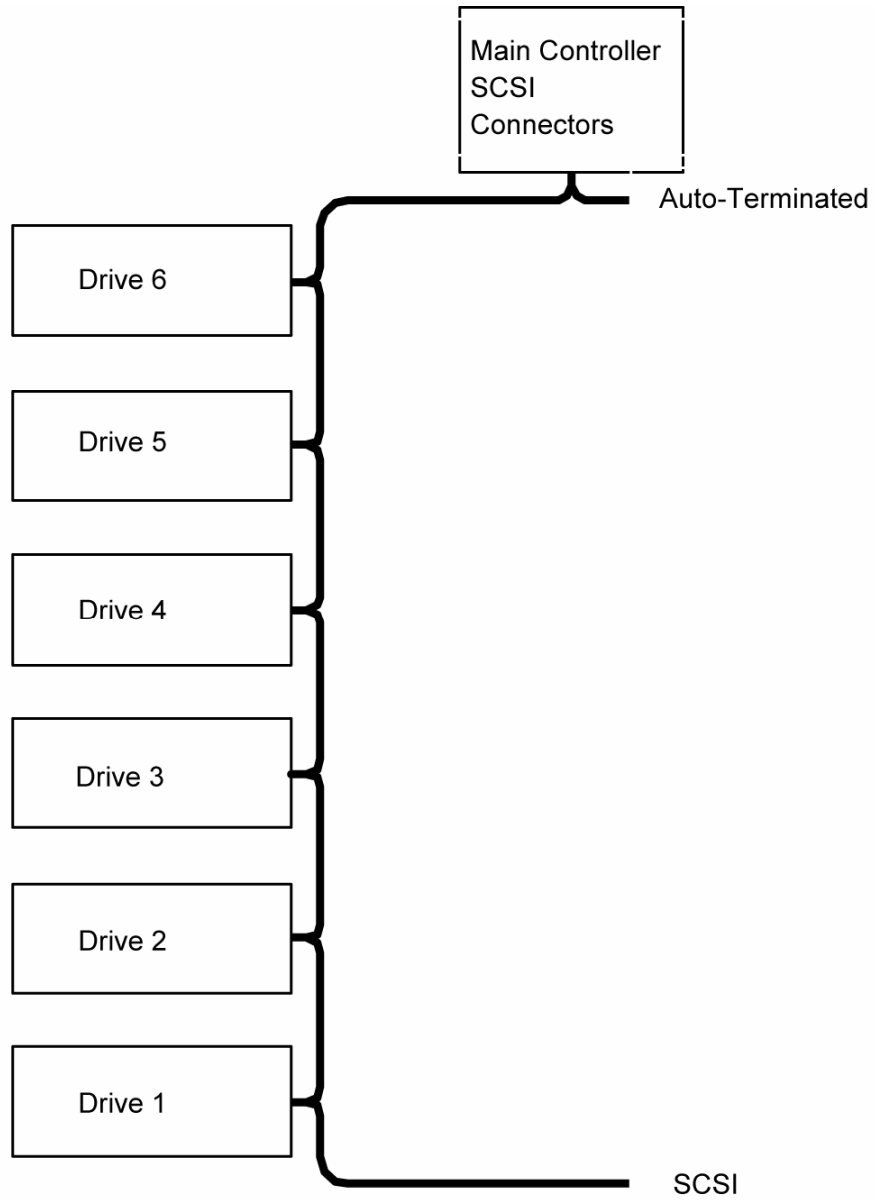

Figure 61. SCSI Bus Configuration for the Gx100 – Gx174 (6 drives)

SCSI ID Configuration

The SCSI IDs are set at the factory to the following settings for the Plasmon Gx libraries.

Table 21. Factory Default SCSI IDs for the Gx (2 drives)

Device	SCSI ID
Robotics	6
Drive 1	0
Drive 2	1

Table 22. Factory Default SCSI IDs for the Gx (4 drives)

Device	SCSI ID
Robotics	6
Drive 1	0
Drive 2	1
Drive 3	2
Drive 4	3

Table 23. Factory Default SCSI IDs for the Gx100 – Gx174 (6 drives)

Device	SCSI ID
Robotics	6
Drive 1	0
Drive 2	1
Drive 3	2
Drive 4	3
Drive 5	4
Drive 6	5

SCSI Cable Applications

Use only qualified SCSI cables supplied by Alliance for connections from a host computer to Plasmon stand-alone library installations, and between a Plasmon AA library and an optional extension library. All cabling must comply with the (SCSI Parallel Interface) SPI-3 or the Ultra-320 universal standard. The library connections are HD68, and host computers may be HD68 or VHDCI.

SCSI Cables

Alliance SCSI cables conform to Ultra 320 Universal SPI-4 standards for low loss. The library connectors are high density 68-pin connectors. The following tables show the allowable cable lengths for each of the SCSI interfaces.

Table 24. SCSI Cable Lengths (Gx24 – Gx32 Series)

SCSI Interface Gx24-32	Max Allowable External Cable Length
LVD (UDO drives only – without Redriver)	31 ft. (9.4 m)
LVD (with LVD SCSI Redriver Installed – UDO, MO or mixed drives)	39 ft. (12 m)

Table 25. SCSI Cable Lengths (Gx20 – 80 Series)

SCSI Interface Gx20-80	Max Allowable External Cable Length
LVD (with UDO drives only – without Redriver)	27 ft. (9.4 m)
LVD (with LVD SCSI Redrive Installed – UDO, MO or mixed drives)	33 ft. (12 m)

Table 26. SCSI Cable Lengths (Gx100 – Gx174 Series)

SCSI Interface Gx100-174	Max Allowable External Cable Length
LVD (with UDO drives only – without Redriver)	27 ft. (8.2 m)
LVD (with LVD SCSI Redrive Installed – UDO, MO or mixed drives)	33 ft. (10 m)

SCSI Redrive Option

The optional SCSI Redrive circuit board (included for all MO drive libraries) isolates the internal SCSI bus from the external SCSI bus, and communicates between the two. This allows maximum external cable lengths.

SCSI Termination

The Plasmon Gx-Series libraries are LVD terminated internally. No external termination is required.

APPENDIX C

SAFETY AGENCY STANDARDS

FCC Notice

The equipment to which this manual pertains has been tested and found to comply with the limits for a Class A digital device, pursuant to part 15 of the FCC Rules. These limits are designed to provide reasonable protection against harmful interference when the equipment is operated in a commercial environment. This equipment generates, uses, and can radiate radio frequency energy and, if not installed and used in accordance with this manual, may cause harmful interference to radio communications. Operation of this equipment in a residential area is likely to cause harmful interference in which case the user is required to correct the interference at his own expense.

Shielded cables are required for this device to comply with FCC rules. Use shielded cables when connecting this device to others.

Industry Canada Notice per ICES-003

English: This digital apparatus does not exceed the Class A limits for radio noise emissions from digital apparatus set out in the interference-causing equipment standard entitled "Digital Apparatus," ICES-003 of the Industry Canada.

French: Cet appareil numérique respecte les limites de bruits radioélectriques applicables aux appareils numériques de Classe A prescrites dans la norme sur le matériel brouilleur: "Appareils Numériques", NMB-003 édictée par l'Industrie Canada.

European Notice

This product bears the **CE** Mark and is in conformance with the EMC directive, low voltage directive, the RoHS 2 directive and the following norms:

EN 55022/CISPR 22, Class A
EN 55024
EN 61000-3-2
EN 61000-3-3

Australia/New Zealand Notice

The Gx24-32, Gx20-174 and AA20-174A12 series equipment, except Elite models, has been tested and complies with AS/NZS 3548.

Japan Notice

Gx24_32、Gx20_174、およびAA20_174A12シリーズは、情報処理装置等電波障害自主規制協議会（VCCI）の基準に基づくクラスA情報技術装置です。この装置を家庭環境で使用すると、電波妨害を引き起こすことがあります。この場合には使用者が適切な対策を講ずるよう要求されることがあります。

The Gx24-32, Gx20-174 and AA20-174A12 series are Class A product based on the standard of the Voluntary Control for Interference by Information Technology Equipment (VCCI). If this equipment is used in a domestic environment, radio disturbance may occur, in which case, the user may be required to take corrective actions.

PRC Notice

The Gx libraries power supplies are certified for China Compulsory Product Certification (CCC).

Product Safety Standards

This library complies with the following domestic and international product safety standards:

- UL Standard 60950-1, 1st Edition: 2003 Safety of Information Technology Equipment
- CSA Standard C22.2 No. 60950-1-03, Safety of Information Technology Equipment
- IEC 60950-1, 1st Edition: 2001
- IEC 60825-1:1993+A1:1997+A2:2001+Amendment 1:2005-11-02

CDRH Regulations

The Center for Devices and Radiological Health (CDRH) of the U.S. Food and Drug Administration implemented regulations for laser products on August 2, 1976. All Alliance Storage Technology, Inc products comply with 21 CFR 1020.10 and 1020.11 except for deviations pursuant to laser notice No 50 dated July 26, 2001.

Laser Safety Notice

This library is a Class 1 Laser Product. Multiple Class 1 UDO optical drives are implemented within the library. The drives and the library both comply with 21 CFR 1010.10, 1040.11, and IEC 60825-1:1993+A1:1997+A2:2001 as Class 1 laser products.

The maximum output power and wavelength of the laser in the Plasmon UDO30 and UDO60 drive is 65mW (403-413nm), in the Sony SMO-F551-W5 drive is 60mW (675-695 nm), and in the Sony SMO-F561 drive is 40mW (655-667 nm). The maximum radiated output power of LEDs within the library is 500uW



WARNING: Internal Laser

Use of controls or adjustments, or performance of procedures other than those specified herein, may result in hazardous radiation exposure.



This Class 1 Laser Product label is placed on the front of the library, inside the front door.

Lithium Battery

No user serviceable batteries exist in the Plasmon Library systems. An Alliance trained technician must perform FRU replacement with qualified Alliance replacement assemblies.

FRUs are available for technicians to replace the lithium batteries in the Archive Appliance SMS motherboard and RAID controller card. The used battery assemblies must be returned to Alliance Storage Technologies Inc. To retired the system, follow disposal instructions below.



CAUTION: Lithium Battery

RISK OF EXPLOSION IF BATTERY IS REPLACED BY AN INCORRECT TYPE

“ATTENTION: IL Y A DANGER D'EXPLOSION S'IL Y A REMPLACEMENT INCORRECT DE LA BATTERIE. REMPLACER UNIQUEMENT AVEC UNE BATTERIE DU MEME TYPE OU D'UN TYPE RECOMMANDE PAR LE CONSTRUCTEUR. METTRE AU REBUT LES BATTERIES USAGEES CONFORMEMENT AUX INSTRUCTIIONS DU FABRICANT.”

Vorsicht! Explosionsgefahr bei unsachgemabem Austausch der batterie. Ersatz nur durch denselbel oder einen vom Hersteller empfohlenen gleichwertigen Typ. Entsorgung gebrauchter Batterien nach Angaben des Herstellers.

Disposal Instructions for Retired Systems:



CAUTION: Hazardous Material Disposal Is Required

Due to internal restricted chemicals, lithium batteries cannot be discarded into public waste management facilities.

Return the retired motherboards, coin batteries and RAID card assemblies to Alliance Storage Technologies Inc. or dispose of spent assemblies at qualified waste recycling facilities for lithium battery chemical extraction and neutralization by law. The recycling service must remove coin batteries from the PCAs by relieving the battery holder clamp or by clipping the soldered legs. RAID battery packs must be clipped free of electrical wiring and separated from plastic wraps.

Power Source Safety

The AA model systems utilize SMS control unit power inlets that are separate from the library unit power inlet. Use precaution to fully disconnect all inlets whenever power must be removed.



WARNING: Multiple Power Sourced Equipment

This equipment is considered to be powered by multiple sources. Disconnect the SMS power by unplugging two power supply inlets at the left rear of the unit. Also disconnect the library power by unplugging the power cord from the power entry module at the lower rear of the library.



WARNING: Wiring

All electrical wiring of UPS, Power Cord Sets or service outlets must be performed by a licensed electrician. Safety ground connection to true earth reference must be verified. Observe the following Power Cord Set requirements.



WARNING: Loss of RAID Data

Loss of SMS RAID data may occur unless specific shut-down procedures are followed. All servicing must be performed by qualified Alliance trained technicians.

Earth Grounding

This appliance requires the power to be sourced from an earth grounded outlet, verified by a licensed electrician.

In Norway

Apparatet må tilkoples jordet stikkontakt.

In Sweden

Apparaten skall anslutas till jordat uttag.

In Finland

Laite on liitettävä suojamaadoituskoskettimilla varustettuun pistorasiaan.

Power Cord Set

See the table below for required power cord sets. Outside the US contact Alliance for country specific requirements. All power cord modification must be done by a licensed electrician.

Table 27. Power Cord Set Requirements

Power Cord Set Requirements									
		US and Canada				Continental Europe			
Cord	Series	Rating	Plug	Cordage	Connector	Rating	Plug	Cordage	Connector
Library to Power Source	All	125V 10A	NEMA5-15P	SJT 3/18AWG	IEC60320 C13	250V 10A	Schuko CEE 7/7	H05VVf3G1.00	IEC60320 C13
NAS to Gx Outlets	A12 & Elite	125V 10A	IEC60320 C14	SJT 3/18AWG	IEC60320 C13	250V 10A	IEC60320 C14	H05VVf3G1.00	IEC60320 C13

U.S. and Canada

Alliance supplied power cord set are CSA labeled: Type SJT, SVT, ST, SJO or SO, 3-conductors, No.18 AWG rated 125V, 10A.

Germany and continental Europe

STROMANFNAHME: 100-240 VAC, 50/60 Hz, 10A

Für eine 230V-Anwendung, ist eine harmonisierte <HAR> konfektionierte Leitungsschnur, Typ H05vvf3G1.00, die für 250V/10A oder die Gleichwertigkeit geeignet ist, zu benutzen.

MOV Protection Fuses

The library fuses are not in-line protection for the power inlet. Rather, the fuses are protection for MOV surge limiters. If the fuses are blown, the internal surge protection device must be replaced by qualified Alliance Storage Technologies Inc service personnel.



CAUTION: Surge Fuses

A HIPOT test is applied to the library during manufacture. To avoid stressing the MOV's, remove the two fuses next to the external AC connector on the lower back of the library before applying test voltage. The fuses take the MOVs and GDTs out of the circuit.

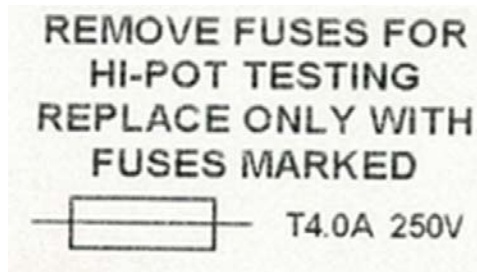

Figure 62. Surge Protection Module Fuses

Uninterruptable Power Source

A facility generator set distribution branch or a local UPS is required for superior robotics and data storage reliability. To properly size a local UPS, use the load requirement in the following table to avoid over-current crowbar due to turn-on surge and initial spin-up. APC UPS models are listed as recommended examples. Note that the load at turn-on is more than the sustained operating load. The sustained load determines the duration of supported service. Select auxiliary batteries as needed for desired support time. Alliance recommends 15 to 30 minutes of battery time.

Table 28. Local UPS Requirements

Local UPS Size Requirements			
SYSTEM TYPE	UPS SIZE	SUSTAINED	APC TYPE
AA40-174 and Elite AA40-174 models	750W min	550W	SMT1000
Gx40-174 models	300W min	300W	SMT750
AA16-32 models	275W min	260W	SMT750
G24-32 models	175W min	175W	SMT750

APPENDIX D

ERROR CODES

Error Codes

Error codes take the form SK-ASC-ASCQ (for example, 04-80-1D). In some cases a four digit subcode is also displayed. The 04 is the Sense Key, the 80 is the Sense Code, and the 1D is the Sense Code Qualifier. There is also a Base Code number that displays on the front panel.

When an error code is generated it is briefly displayed on the front panel LCD screen. After a short time the display reverts to the normal state with a “?” on the Selection Button Indicator line as shown below.

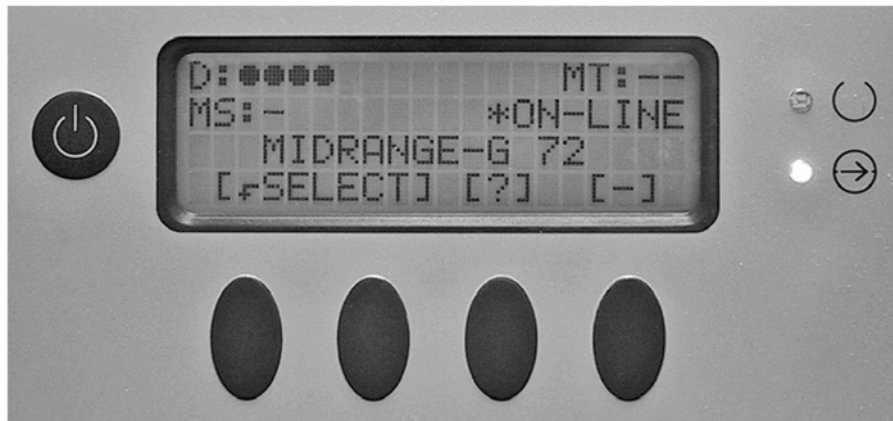

Figure 63. Error Indicator on Display

Pressing the selection button below the “?” brings the error code display back to the screen as shown below.



Figure 64. Error Code on Display

Error Code List

Table 29. Error Codes

Sense Key	Sense Code	Qualifier	Base Code	Error Description
00	00	00	00	Unknown error
01	80	00	2E	The library experienced a problem, but recovered. Check the library error logs for more information.
01	80	4A	23	Barcode scanner reset during scan.
02	04	01	01	The library may be having a problem during initialization. Retrieve errors from error log.
02	04	82	04	A motor is continuing to run and the library cannot become ready.
02	04	83	05	Library is parked.
02	04	84	06	Not Ready, programming DSP. The DSP believes it is being programmed and the library does not become ready. Wait until it completes.
02	04	86	32	Picker 1 or picker 2 is full at power up and unable to export the media.
02	04	88	3D	Not Ready, utility slot full. The two utility slots below the I/O station may have media present.
02	04	89	2F	Initialization of the library failed at power on.
02	80	2C	29	Mailslot door is open.
04	44	00	18	Internal target failure. Main Controller reset has occurred.
04	52	59	56	Unexpected media type (UDO vs. MO) during a pick operation.
04	80	01	1B	Flash checksum error. Checksum was incorrect during firmware download.
04	80	0E	1C	Flash program fail - main controller
04	80	0F	1D	Flash program fail - DSP. DSP failed to program during a firmware download.
04	80	1D	1F	Element unexpectedly empty. Library believes the storage slot or I/O station should have media present.
04	80	1E	20	Element unexpectedly full. Library believes the storage slot or I/O station should be empty.
04	80	20	21	Pick cartridge failure during an attempt to get a cartridge from a slot, drive, or the I/O station.
04	80	21	22	Store cartridge failure during an attempt to put a cartridge into a slot, drive or the I/O station.

Sense Key	Sense Code	Qualifier	Base Code	Error Description
04	80	24	24	Drive load failure during an attempt to load media into a drive. Media was placed into a drive, but the drive did not load the media onto the hub and become ready.
04	80	25	25	The robotics did not see media ejected from a drive.
04	80	26	26	The robotics did not see media ejected from a drive.
04	80	29	27	The power supplied for SCSI termination is low.
04	80	2F	2A	Failure of the lift assembly to pivot.
04	80	32	2B	Lift could not position to its destination.
04	80	35	2D	The MTA failed to flip.
04	80	3C	30	The MTA failed to swap pickers.
04	80	43	33	Media is not in the I/O station, but the library sees the I/O door is open.
04	80	49	36	Barcode scanner not installed. Library is asked to scan a barcode, but scanner is turned off or not installed.
04	80	4A	28	Loss of communication between library Main Controller and barcode reader.
04	80	4B	38	Barcode reader returned a status indicating a failure in operation.
04	80	4E	39	Drive is not responding to the library Main Controller.
04	80	52	3A	The picker cannot load media into the mailslot.
04	80	54	3B	Bad drive type. The drive type (UDO vs. MO) returned to the controller is not correct.
04	80	5D	42	Library has reached the 113°F (45°C) overheat condition
04	80	5E	43	Library shutdown due to temperature reaching 115.7° F (46.5°C).
04	80	5F	44	Library shutdown due to fan failure
04	80	62	45	Front fan failure
04	80	63	46	Rear fan failure
04	80	64	47	Power supply voltage is out of specification.
04	80	65	48	Power supply failure.
04	80	70	51	Communications timeout with DSP. Loss of communication between the DSP and the CPU on the Main Controller CB.
04	80	71	53	Library Main Controller cannot communicate with the drive.
04	80	82	67	Failed DSP communication. DSP is not communicating with the CPU on the Main Controller CB.
04	80	83	68	Library Main Controller DSP did not respond.

Sense Key	Sense Code	Qualifier	Base Code	Error Description
04	80	90	5B	Flip calibration failure during library initialization.
04	80	91	5C	Pick calibration failure during library initialization.
04	80	92	5D	Lift calibration failure during library initialization.
04	80	93	5E	Pivot calibration failure during library initialization.
04	80	94	50	DSP full cal error. During the calibration or initialization process a motor failed to complete its process.
04	80	96	61	Mailslot offset failure during library initialization.
04	80	97	5F	Alignment calibration failure. A mechanical failure occurred during the initialization or calibration process.
04	80	98	4E	Media is detected in one or both of the utility slots located below the I/O station.
04	80	99	4D	The flash of the CPLD program failed during library initialization.
04	80	9B	49	The front panel display cannot be accessed by the Main Controller CB, or a host application controls the keypad.
04	80	9C	37	The Lift vertical path is blocked.
04	80	FF	69	Library Main Controller failure.
04	88	01	64	Auto Offset sensor that detects the frame cutouts failed.
04	88	02	41	During a put or get operation the MTA is not level.
04	88	03	3F	During a flip operation, the A/B side sensor was not detected.
04	88	04	1E	During a put, get, or flip operation the motor failed to move or was obstructed.
04	88	05	40	Picker Home sensor not detected.
04	88	06	4C	During a vertical lift movement the encoder was not seen.
04	88	07	63	Mailslot Home sensor is not detected, or mailslot is not at the home position.
04	88	08	34	During a check of the mailslot door sensor and media present sensor, the states are invalid.
04	88	09	62	During initialization the correct lift motor is not detected.
04	88	0A	12	Pick/Flip motor or encoder failure. During a put or get operation the Pick/Flip motor or encoder is failing.
04	88	0B	N/A	During Library Verify the barcode test failed.
04	88	0C	N/A	During the Library Verify test a SCSI failure occurred.
04	88	0D	N/A	Drive failed R/W test during Library Verify test, or UDO drive failed the R/W test.

Sense Key	Sense Code	Qualifier	Base Code	Error Description
04	88	0E	N/A	Media is inserted into the I/O station, but is not detected.
04	88	0F	0E	Drive is not UDO (IBM 3996 only).
04	88	10	3E	Library configuration error (IBM3996 only).
04	88	11	3E	Scan Media sensor failure. Media is placed into a utility slot to test the Scan Media sensor but media is not detected.
04	88	88	16	The mechanics relating to pivot calibration are off such that the Auto Offset sensor breaks before the Pivot Home sensor causing the pivot calibration to fail.
04	8F	01	6A	Tried to execute a command while no slot license is defined.
04	8F	02	6B	Media in unlicensed slots
04	8F	04	6D	Attempt to set license key to invalid drive/# slots configuration
05	1A	00	07	Parameter list length error
05	20	00	08	Invalid command, operation code
05	21	01	09	Invalid element address
05	24	00	0A	Invalid field in CDB
05	25	00	0B	Logical Unit not supported
05	26	00	0C	Invalid field in Parameter list
05	3B	0D	13	Media destination element full
05	3B	0E	14	Media source element empty
05	3D	00	5A	Invalid identify message
05	52	5A	57	Attempt to place MO media in UDO drive
05	52	60	60	Attempt to place UDO media in MO drive
05	53	02	1A	Media removal prevented
05	80	4A	4A	Both pickers are needed for this exchange
05	80	55	3C	Drive address conflict
05	80	AA	4B	Position element command reduced access storage error
05	81	03	65	Download checksum error
05	86	00	66	Transport element full
05	8F	03	6C	Attempt to downgrade to non-licensed firmware
06	29	00	0F	Power on, Reset, or Bus Device Reset occurred
06	2A	00	10	Log contents changed
06	2A	01	11	Mode Parameters changed
06	2F	00	52	Command Aborted by another initiator
06	3F	01	17	Microcode has changed
06	82	80	31	MTA full at power up and exported

Sense Key	Sense Code	Qualifier	Base Code	Error Description
0B	43	00	59	Message error
0B	45	00	2C	Library unable to reselect the host
0B	47	00	55	Parity error
0B	48	00	54	Initiator detected error
0B	4E	00	19	Overlapped commands
0B	83	00	35	Barcode scan abort - media in MTA

Error Subcode List

Table 30. Subcodes

Subcode	Description
0001	Lift Stall
0002	Lift Timeout
0003	DSP communication error
0007	Lift position overshoot/servoing error - Lift is having trouble servoing to position at the end of a move
0009	Lift motor or encoder failure.
000A	Auto Offset Sensor Failure
000B	MTA is not straight, tilt in MTA exceeds specifications
000C	Lift motor encoder failure.
000D	Auto Offset sensor immediate. A fault where retries could cause mechanical damage, so retries are aborted
0010	Number of counts specified for a stepper exceeds maximum limit
0016	Pick Flip Encoder Error
0018	Stepper motor error
0019	Stepper homing error
001A	Stepper servoing error
001B	Picker 1 or 2 Home Sensor failure
001C	Flip Sensor Failure A or B
001D	Flip Failure
001E	Pivot Failure
0030	Auto Offset sensor failure
0031	Auto Offset sensor and/or pivot home sensor failure
0032	Pick calibration failure
0033	Flip calibration failure
0035	Alignment calibration failure (MTA)
003D	Auto Offset and Pivot sensors are seen in the wrong order
0040	Mailslot error
0042	Picker 1 and 2 Home Sensor error when attempting to retract mailslot
0043	Mailslot Home sensor did not change when mailslot was retracted

Subcode	Description
0044	Picker 1 and 2 Home Sensor error when mailslot is extended
0045	After extending the mailslot the Mailslot Home sensor is not correct
0046	MTA empty after picking from mailslot
0047	MTA still has media after putting to mailslot
0050	Media detected in utility slot 1
0051	Media detected in utility slot 2
0052	Media detected in both utility slots
0053	Media found in utility slot 1 has been exported to the mailslot
0054	Media found in utility slot 2 has been exported to the mailslot
0057	During an MTA calibration, media temporarily stored in the utility slot was not retrievable
0060	During calibration the MTA hung up in the mailslot
0061	During calibration the mailslot home sensor showed mailslot pulled into library
0062	During calibration an obstruction was detected in the main column
0063	During calibration an obstruction was detected in the offset column
00C0	Scan Media Sensor stuck high
00C1	Scan Media Sensor stuck low
00C2	Scan Media sensor reversed
00C3	SCSI drive test failed, no SCSI Response
00C4	SCSI drive test failed, drive never becomes ready
00C5	Drive test failed, drive returned error code
00C6	Drive test failed, drive stopped communicating mid test
00D0	Drive eject fault after timeout (90 seconds) because host did not or could not eject media
00D1	Drive 1 failed
00D2	Drive 2 failed
00D3	Drive 3 failed
00D4	Drive 4 failed
00D5	Drive 5 failed
00D6	Drive 6 failed

INDEX

Archive Appliance SMS Service Manual	13
automated IO station	13
automated mailslot	31
barcode label	19
battery	118
bus configuration, SCSI	112
cable	
power	37, 63
SCSI	113
capacity	
drives	14
library	99
media	14
cartridge	
UDO	13
CDRH	117
cleaning cartridge, drive	16
command processing	15
connection	
power	37
SCSI	39
connector	
power	31
customer support	133
description line	69
display	
front panel	31
disposal	118
drive	
capacity	14
cleaning	16
type	16, 99
ERROR CODES	122
error subcodes	128
FCC	115
front panel display	31, 92
fuses	120
grounding	119
hardware components	21
HDD	85
host computer	42
IAC	91
IO station	31, 41
laser	117
LCD display format	71
LCD symbols	71
LED	
activity	69
on line	69
library	
hardware components	21
models	14
options	71, 99
position	33
stabilizers	34
status menu	74
lift lock screw	31
mailslot	31, 41, 92
main menu overview	73
maintenance mode overview	80
max drive capacity	14
media	40
care and handling	20
importing and exporting	15
loading	40
movement	15
store	31
transport element	31
write protecting	18
menu system	
LCD display format	71
LCD symbols	70, 71
library status menu	74
main menu	73
maintenance mode menu	80
navigating	69
power up menu options	71
set up library menu	77
models, library	14
operator panel	31
options	71, 99
packing instructions	63
position, library	33

power		cable.....	113
connection.....	37	connection.....	39
connector.....	31	ID configuration	112
consumption.....	99	interface	31
cord	37	redrive.....	32
requirements.....	33, 99	SCSI bus.....	109
power cord set.....	120	selection button indicators.....	69
power safety.....	119	setup library menu.....	77
power source.....	119	SMS.....	13, 85
power-down	96	specifications.....	99, 103, 105, 107
power-up.....	96	SSD	85
		standards.....	116
RAID	13, 85, 92, 93, 96	technical support.....	133
redrive, SCSI.....	32		
SAFETY AGENCY STANDARDS.....	115	UDO	13, 16, 92, 99, 102
SAS.....	85, 92, 93	UDO drive cleaning cartridge.....	16
SATA.....	85, 92, 93, 97	UPS	121
SCSI		warranty.....	6
bus configuration	112		

Contacting Alliance

World Wide Technical Support	
Alliance Technical Support	1-877-585-6793 (United States Calls) 01-719-593-4437 (International Calls)
	1-719-593-4164 (fax)
e-mail	tech.support@astiusa.com
Internet	www.astiusa.com

Firmware Updates

Contact Alliance or your reseller for the latest firmware updates.

Before Placing a Call to Alliance

Register your site on-line at <http://www.plasmontech.com/warranty/index.html>.

Placing a Service Call

Contact your service provider directly. If Alliance is your service provider, please have the following information available when calling:

- Serial number
- Description of failure
- System Information
 - Computer type and SCSI adapter
 - Software configuration
 - Software and version number

